

LiFePO₄

51.2V 200AH LIFEP04 BATTERY WALL MOUNTED MANUAL

Operation and Maintenance

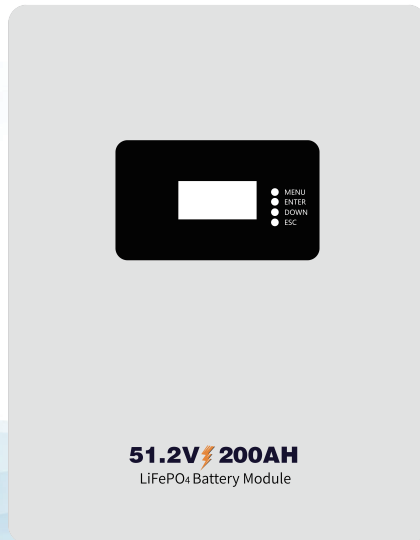

SUPPORT

If you are experiencing technical problems and cannot find a solution in this manual, please contact us for further assistance.



Description

This manual describes in detail the requirements and procedures for safe installation and operation of us lithium battery pack. Please read this manual carefully. Only qualified persons are allowed to install, operate and maintain the system, otherwise it may cause product damage or personal safety risks.

Any actions against safety operation, or do not follow rules of this manual and limited warranty letter, will void warranty and qualification of this product. Meanwhile, the manufacturer will be not responsible for the product damage, property damage, personal injury or even death.

The information contained in this manual is accurate when it's issued. We reserves right to change specification (such as optimization, upgrade or other operations) without prior notice, and please always view the latest document via QR code on the label.

In addition, please noted that the diagrams/schematics in this document are used to help understand system configuration and installation instructions, which may be different from the actual items in the installation.

Contents

I. Information	1
1.1 Validity	1
1.2 Target Group	1
1.3 Levels of warning messages	1
1.4 Symbol Description	2
1.5 Abbreviation Description	3
II. Safety	4
2.1 Safety precautions	4
2.2 Safety instructions	4
2.2.1 Safety gear	5
2.2.2 Emergency safety measures	5
2.2.3 Other Tips	6
III. Product Overview	6
3.1 Introduction	6
3.2 Features	7
3.3 Specification	8
3.4 Protection	15
IV. DISPLAY	16
4.1 Display dimension	16
4.2. Pages description	17
4.2.1. HOME	17
4.2.2. Pack information	17
4.2.3. Pack Status	18
4.2.4. Pack Parameters(Unfinished)	18
4.2.5. Pack Settings	19
V. Lithium Battery IoT Cloud	20
5.1 Introduce	20
5.2 APP use	21

VI. Installation	22
6.1 Preparation.....	22
6.1.1 Safety Compliance	22
6.1.2 Environment	22
6.1.3 Tools.....	22
6.2 Inspection.....	23
6.2.1 Unpack precautions.....	23
6.2.2 Scope of delivery.....	23
6.3 Start Installation.....	25
6.3.1 Remainder	25
6.3.2 Procedures	26
VII. Cable Connection and Commissioning	27
7.1 Get battery ready.....	27
7.2 Communication cable connection	27
7.3 DC power cable connection	28
7.4 Connecting with inverter.....	28
7.5 Commissioning.....	30
7.6 Switch off battery.....	30
VIII. Troubleshooting	31
IX. Transport and Storage	32
X. Disposal of battery	32
XI. Technical Support	33

I. Information

1.1 Validity

This document is valid for: LFP48200-BG

1.2 Target Group

This document is intended for qualified persons and operators. Only qualified persons are allowed to perform activities marked with a warning symbol and the caption "Qualified person" in this document. Qualified persons must have the following skills:

- * Knowledge of how lithium iron phosphate batteries work and are operated.
- * Knowledge of how an energy storage system (including PV/battery/hybrid inverter, MPPT, Meter, Distribution box etc.) works and is operated.
- * Knowledge of local applicable connection requirements, standards, and directives.
- * Training in the installation and commissioning of electrical devices, batteries.
- * Training in how to deal with the dangers and risks associated with installing, repairing and using electrical devices and batteries.

1.3 Levels of warning messages

The following levels of warning messages may occur when handling the product.



DANGER

Indicates a hazardous situation which, if not avoided, will result in death or serious injury.



WARNING

Indicates a hazardous situation which, if not avoided, could result in death or serious injury.



CAUTION

Indicates a hazardous situation which, if not avoided, could result in minor or moderate injury or product permanent damage.

**NOTICE**



Indicates a situation which, if not avoided, can result in property damage or product not work or accelerated product damage.

1.4 Symbol Description

1.4.1 Symbols on products label

Symbols	Definition
	Indicates the danger of electric shock. If not avoided, it would cause casualties.
	Indicates a potentially dangerous condition which could result in injury or death.
	Indicates important information or warnings related to concepts talked about in the text.
	Indicates more information is available in other documents relating to the subject and reader.
	Indicates important steps or tips for optimal performance.
	Do not place the battery within children/pet touchable area.
	Do not place the battery near heat source and flammable material.
	Do not expose the battery to direct sunlight, rain and snow.
	Do not short circuit the battery.
	Recycle label
	WEEE designation

1.4.2 Other symbols

Label	Definition
 Qualified person	Indicates activities that can only be performed by qualified persons
	Grounding point

1.5 Abbreviation Description

Abbreviation	Definition
Battery/battery pack/battery module	Single LFP48200-BG rechargeable lithium iron phosphate battery pack including cells, BMS and enclosure etc.
Battery system/ cluster	Multiple LFP48200-BG battery pack connected in parallel with power, communication and grounding cables and installation auxiliaries.
BMS	Battery management system Electronical Unit to ensure lithium cells' safety and display information or control the battery work mode.
SOC	State of charge The battery state of charge refers to the percentage of the remaining capacity and rated capacity of the battery.
SOH	State of health The battery health status refers to the percentage between the full charged capacity and the rated capacity of the battery.
DIP switch	Dual in-line package switch

II. Safety

2.1 Safety precautions



- Do not impact the battery with heavy objects.
- Do not squeeze or pierce the battery pack.
- Do not throw the battery pack into the fire.



- Fire risk
- Do not expose the battery pack to the condition over 80°C.
 - Do not put the battery near a heat source, such as a fireplace.
 - Do not expose the battery pack to direct sunlight or raining.



- Electric shock risk
- Do not allow non-qualified person to disassemble the battery pack.
 - Do not touch the battery pack with wet hands.
 - Do not expose the battery pack to moisture or liquid environment.



- Damage risk
- Do not short-circuit or reverse connect the battery.
 - Do not use chargers or charging devices unapproved by the manufacturer to charge the battery.
 - Do not mix batteries from different manufacturers or different kinds, types or brands.

2.2 Safety instructions

The battery has been designed and tested in accordance with international (such as UL, IEC, UN38.3 etc.) safety requirements. However, Due to various factors during the whole lifetime process, We cannot guarantee absolute safety, in order to prevent personal injury and property damage and ensure long-term operation of the battery, please do read and following the below section carefully to operate the battery and handle emergency situations.

2.2.1 Safety gear

It is required to wear the following safety gear when installing and handling the battery pack.



Insulated gloves



Safety Glasses



Safety Shoes

2.2.2 Emergency safety measures

* Water invasion

Please cut off the AC power supply of the system first and then disconnect all switches under the premise of ensuring safety.

* Electrolyte or gas leakage

If the battery pack leaks electrolyte, avoid contact with the leaking liquid or gas. If one is exposed to the leaked substance, immediately perform the actions described below.

•Gas Inhalation: Evacuate the people from the contaminated area and seek medical aid immediately.

•Eye Contact: Flush your eye with clean and flowing water for 15 min, and then seek medical aid immediately.

•Skin Contact: Thoroughly rinse the exposed area with soap and water to be sure no chemical or soap is left on them, and seek medical aid immediately.

•Ingestion: Induce vomiting, and seek medical help immediately.



WARNING

In case of fire situations, please use carbon dioxide fire extinguisher rather than liquid to put out fires.

2.2.3 Other Tips

- All the product are strictly inspected before shipment, Please contact us for replacement if you notice there are any defectives such as swelling etc.
- Do not disassemble batteries and components, otherwise the manufacturer will not be responsible for any damage caused by unauthorized disassembly or repair.
- Enable the battery to be safely grounded before use to make sure the system in safe and normal operation.
- Please ensure that the electric parameters of these devices are compatible mutually before connecting the battery to other devices.
- Please take the environmental factors into careful considerations to ensure that the system can work in a suitable condition as the environment and storage methods have a certain impact on the service life and reliability of this product.

III.Product Overview

3.1 Introduction

The LFP48200-BG battery is designed for residential application and works as a storage unit in the photovoltaic system. It is a 48V Li-ion battery storage system, with BMS inside itself. It could be operated in both on-grid, back-up and off-grid modes with compatible inverters. Below is the general schematic of an ac-coupled system.

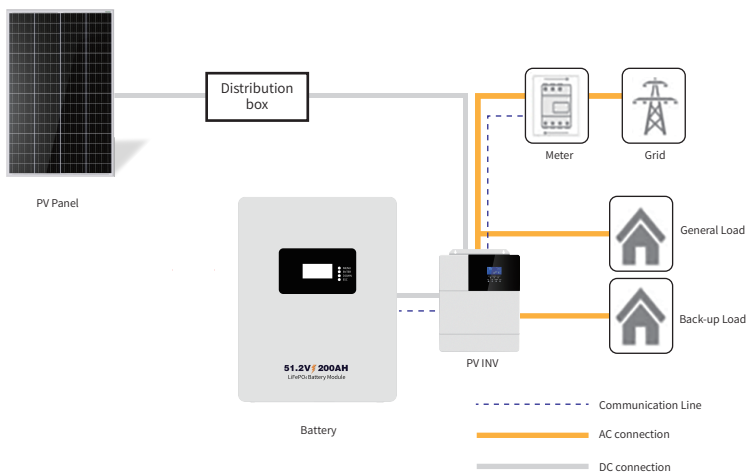



This electrical connection in this diagram is only for illustration, please follow the Manual suggestions of related devices and operate in accordance with locally applicable connection requirements, standards, and directives.

3.2 Features

- Highest safety, battery is made from LiFePO₄ chemistry and comply with highest international safety and transport standard.
- Modular and flexible, support up to 15 batteries connect together to expand the system energy.
- Build-in pre-charge circuit to avoid rush current when connecting with different inverter/chargers.
- Automatic dynamic addressing function when connected multiple batteries together.
- Rapid shut down function for North American market.
- Support a maximum of 96% DOD under off-grid and back-up application
- Built in BMS provide warning and protection functions including over-discharged, over-charged, over-current, short-circuit and high/low temperature.
- LiFePO₄ as cathode material and automatic balancing function to meet long cycle life
- Compact size and light weight for easy installation and maintenance.
- CAN/RS485 port for external communication and upgrade the BMS firmware.

3.3 Specification

3.3.1 Dimension

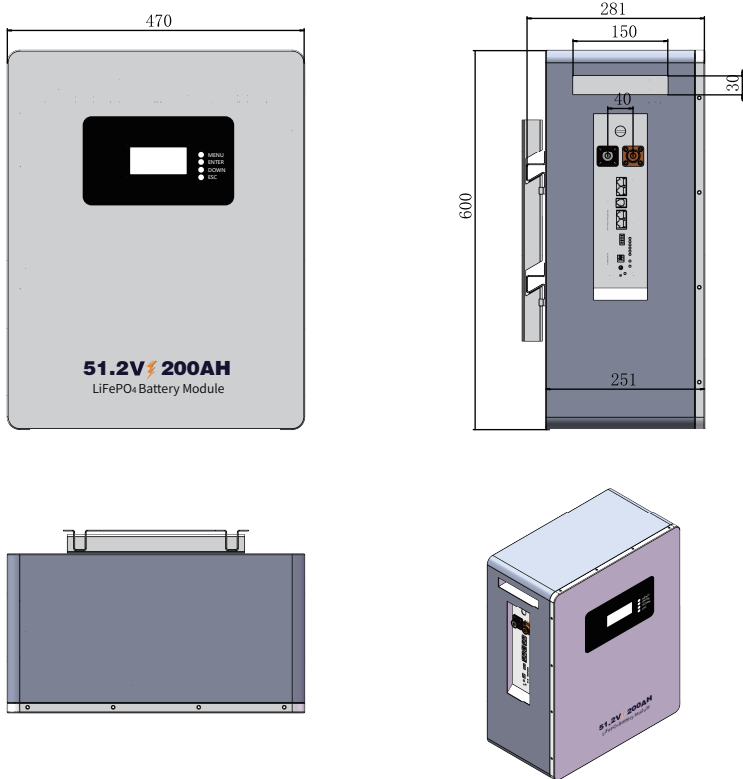

3.3.2 Parameters

Items	LFP48200-BG
Rated voltage	51.2V
Max. voltage range	40~58.4V
Charge voltage	58.4V
Low voltage cut-off	40.0V
Nominal energy	10.24KWh
Usable energy	10.24KWh
Nominal capacity	200Ah

Dimension	23.62*15.80*11.06in/60.0*47.0*28.1cm	
Weight	209.44lb/95kg	
Standard charge current	≤100A	
Max. charge current	200A	
Standard discharge current	≤100A	
Max. discharge current	200A (initial temp. ≤35°C)	
Communication	RS485 /CAN/RS232	
Max. parallel number	15pcs	
Operating temperature	Charge: 0~55°C Discharge:-20~55°C	
Storage temperature	-20~25°C	Less than 1 year
	20~40°C	less than 3 months
	Environment at the shipment state	60±25%R.H.



NOTICE
 The optimum operating temperature range is from 15°C to 30°C, Frequent exposure to the harsh temperatures may worsen the performance of the battery pack and cycle life.

3.3.3 Panel Interface

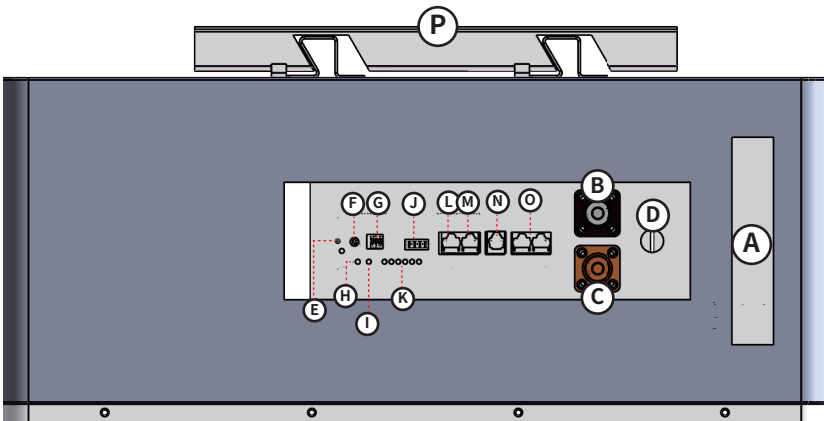

NO.	Items	Usage description	Remark
A	Handles	For handling, intallation and disassembly of battery	
B	Negative terminal	Used to connect the inverter/charger	
C	Positive terminal	Used to connect the inverter/charger	
D	Power switch	Used to Power on/off battery	
E	ON/OFF indicator	Indicates whether the battery is turned on or off	
F	Reset	Used to reset the BMS	
G	ADD	Used to set the RS485 baud rate and inverter protocol choosing	
H	RUN	Used to show battery is in running status when lighting or flashing	
I	ALM	Used to show battery Alarm/Protection status	
J	Dry contact	2 channels output signal 1 channel input signal	Pin1 on the left
K	SOC	Used to show battery real-time SOC	
L	RS485-1	Connect to host computer/inverter	
M	CAN	Connect to host inverter	
N	RS232	Host computer communication interface	
O	RS485 IN RS485 OUT	For communication between batteries	
P	Mounting ear	Used to fix with rack or cabinet	

3.3.3.1 I: ADD

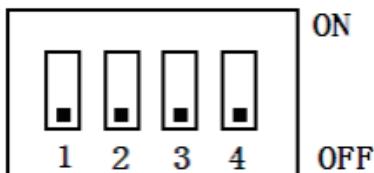

By setting the address through the dip switch on the BMS to distinguish different PACKs, it is necessary to avoid setting the address to be the same. The definition of the BMS dip switch refers to the table below, and the system supports a maximum of 15 parallel machines.

ADD	Explain				
	4	3	2	1	
0000(0)	OFF	OFF	OFF	OFF	Single Battery
0001(1)	OFF	OFF	OFF	ON	SET TO PACK1(MAIN)
0010(2)	OFF	OFF	ON	OFF	SET TO PACK2
0011(3)	OFF	OFF	ON	ON	SET TO PACK3
0100(4)	OFF	ON	OFF	OFF	SET TO PACK4
0101(5)	OFF	ON	OFF	ON	SET TO PACK5
0110(6)	OFF	ON	ON	OFF	SET TO PACK6
0111(7)	OFF	ON	ON	ON	SET TO PACK7
1000(8)	ON	OFF	OFF	OFF	SET TO PACK8
1001(9)	ON	OFF	OFF	ON	SET TO PACK9
1010(10)	ON	OFF	ON	OFF	SET TO PACK10
1011(11)	ON	OFF	ON	ON	SET TO PACK11
1100(12)	ON	ON	OFF	OFF	SET TO PACK12
1101(13)	ON	ON	OFF	ON	SET TO PACK13
1110(14)	ON	ON	ON	OFF	SET TO PACK14
1111(15)	ON	ON	ON	ON	SET TO PACK15



NOTICE

Fail to follow the DIP switch setting will cause the communication fault between battery and inverter, for more detail setting with different inverter/charger, please contact your supplier or us for consultation.

3.3.3.2 RS232 communication Interface Pin Diagram

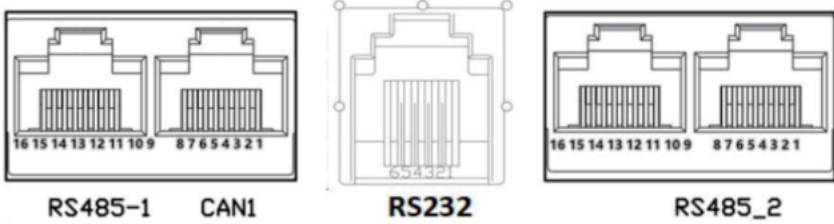

Communication Port	RS485-1		CAN1		RS232		RS485-2	
Functional Description	Connect to host computer/inverter		Connect to host computer/inverter		Connect to host computer		Parallel communication	
Pin Description	PIN	Description	PIN	Description	PIN	Description		RS485-B2
	1, 8	RS485-B1	1, 8	NC	1, 2, 6	NC	1, 8	RS485-A2
	2, 7	RS485-A1	2, 7	NC	3	TX	2, 7	NC
	4	NC	4	CANH1	4	RX	4, 5	NC
	5	NC	5	CANL1	5	GND	3	IN/OUT
	3, 6	GND	3, 6	GND			6	GND

3.3.3.3 Parallel Wiring Instructions

1#

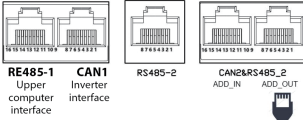

2#

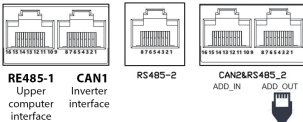

3#

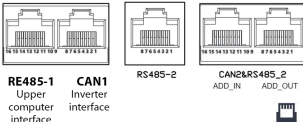

13#

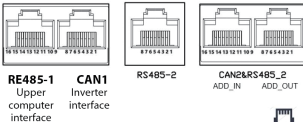

14#

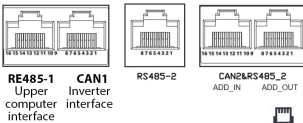

15#

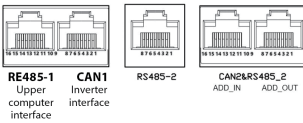

Example of parallel dialing method

The dialing address follows ABIC encoding



PACK 1 address is 1
Dial 1/6 to ON



PACK 2 address is 2
Dial 2/6 to ON



PACK 3 address is 3
Dial 1/2/6 to ON



PACK 13 address is 13
Dial 1/3/4/6 to ON



PACK 14 address is 14
Dial 2/3/4/6 to ON



PACK 15 address is 15
Dial 1/2/3/4/6 to ON

Example of automatic address allocation and parallel operation



Automatically assigned as PACK 1 according to the wiring sequence.



Automatically assigned as PACK 2 according to the wiring sequence.



Automatically assigned as PACK 3 according to the wiring sequence.



Automatically assigned as PACK 13 according to the wiring sequence.



Automatically assigned as PACK 14 according to the wiring sequence.



Automatically assigned as PACK 15 according to the wiring sequence.

3.3.3.4 LED Display Description

System Status	event	ON/OFF	RUN	ALM	SOC(LED 6~1)						Description
					LED1	LED2	LED3	LED4	LED5	LED6	
Shutdown	Dormancy	OFF	OFF	OFF	OFF	OFF	OFF	OFF	OFF	OFF	All OFF
Standby	Normal	ON	Flash 1	OFF	Refer to the table below						Standby
	Warning	ON	Flash 1	Flash 3							/
Charge	Normal	ON	ON	OFF	According to battery state of charge (highest SOC LED: FLASH2)						/
	Warning	ON	ON	Flash 3							Overcharge alarm ALM does not flash
	Overvoltage protection	ON	ON	OFF	ON	ON	ON	ON	ON	ON	/
	Temperature, overcurrent, Fail-safe	ON	OFF	ON	OFF	OFF	OFF	OFF	OFF	OFF	/
Discharge	Normal	ON	Flash 3	OFF	According to battery state of charge						/
	Warning	ON	Flash 3	Flash 3							
	Temperature, overcurrent, Fail-safe	ON	OFF	OFF	OFF	OFF	OFF	OFF	OFF	OFF	Stop discharging
	Overcurrent, short circuit, temperature, failure protection	ON	OFF	ON	OFF	OFF	OFF	OFF	OFF	OFF	Stop discharging
Failure	Cell disconnection, temperature disconnection,AFE sampling failure,discharge MOS failure	OFF	OFF	ON	OFF	OFF	OFF	OFF	OFF	OFF	Stop charging and discharging

State		Charging status						Discharge status					
LED		LED 1	LED 2	LED 3	LED 4	LED 5	LED 6	LED 1	LED 2	LED 3	LED 4	LED 5	LED 6
SOC (%)	0 ~ 16.6%	OFF	OFF	OFF	OFF	OFF	Flash 2	OFF	OFF	OFF	OFF	OFF	ON
	16.6 ~ 33.2%	OFF	OFF	OFF	OFF	Flash 2	ON	OFF	OFF	OFF	OFF	ON	ON
	33.2 ~ 49.8%	OFF	OFF	OFF	Flash 2	ON	ON	OFF	OFF	OFF	ON	ON	ON
	49.8 ~ 66.4%	OFF	OFF	Flash 2	ON	ON	ON	OFF	OFF	ON	ON	ON	ON
	66.4 ~ 83.0%	OFF	Flash 2	ON	ON	ON	ON	OFF	ON	ON	ON	ON	ON
	83.0 ~ 100%	Flash 2	ON	ON	ON	ON	ON	ON	ON	ON	ON	ON	ON
RUN LED		ON						Flash 3					

LED Flashing Description

FLASH Type	ON	OFF
FLASH1	0.25S	3.75S
FLASH2	0.5S	0.5S
FLASH3	0.5S	1.5S

3.4 Protection

Items	Description	Remark
Charge End Cell/ PACK high-voltage	The BMS will stop charging if any cell or PACK voltage reaches the protection value and it will be auto-released only when both Pack and cell voltage back to the release voltage range or there is efficient discharge current.	
Discharge End Cell/ PACK low-voltage	The BMS will stop discharging if any cell or PACK voltage is under the protection value and it will be released only when all the cell voltage back to the release voltage range or there is efficient charge current.	It can automatically recover. Please charge timely, otherwise it may be in Low-power mode to be over-discharged.
High temperature	The BMS will halt charging, discharging, or both if any cell, environmental, or MOSFET temperature falls outside the acceptable range.	Automatic recovery
Low temperature	The BMS will stop charging or discharging or both if any cell/environment/MOS temperature is under the range.	Automatic recovery
Charge over-current	The BMS will stop charging when the charging current is higher than the protection value. And it will release from the protection when the system delays time is met.	It can automatically recover. If locked after three consecutive times, manual intervention is required.
Discharge over-current/ Overload	The BMS will stop discharging when the discharging current is higher than the protection value. And it will release from the protection when the system delays time is met	Automatic recovery. If locked after three consecutive times, manual intervention is required.
Short-circuit/ Reversed	Short-circuit and Reversed polarity protection happened	Charge to release Manual reset
Temperature, Voltage, Current sensor failure	Enter the failure mode, manual intervention is required no charging and discharging.	Manual intervention
Dormancy mode	After reaching a certain condition, it will be in the dormancy mode	Recoverable

 **CAUTION**
Please re-charge the battery via solar, grid/generator or other energy source within 24h if the battery is over discharged.

 **NOTICE**
Manually short-circuit and reverse the battery will void the warranty.

IV. DISPLAY

4.1 Display dimension

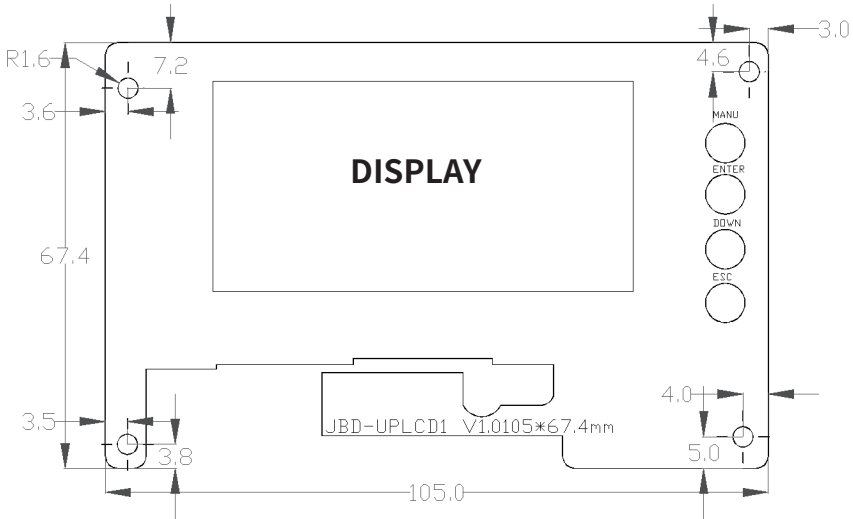

Number	Label	Function	Notes
1	Button 1	Main menu	Start the screen or get back into the main page
2	Button 2	Enter	Select and get into the page
3	Button 3	Down	Move the selection down
4	Button 4	Esc	Escape from current page

4.2.Pages description

4.2.1.HOME

```
->PackInfo    >>
--PackStatus  >>
--PackPara    >>
--PackSet     >>
```

Name	Definition
Pack Info(Pack information)	This page allows you to view voltage, current, temperature, and other data.
Pack Status	This page allows you to view the protection status, protection times, and protection flags.
Pack Para(Pack parameters)	This page can set some protection parameters and is currently not open.
Pack Set(Pack settings)	This page allows you to set the host RS485 protocol or CAN protocol for BMS.

Note: If no operation is performed, the system will shutdown after a delay of one minute.

4.2.2.Pack information

```
->Vol:  0.00V
--Cur:  0.00A
--Capacity >>
--Temp   >>
```

- * Vol(Voltage): Battery pack voltage
- * Cur(Current): Charging/discharging current

```
RSOC:  0.00%
ReMain: 0.00AH
FCC:   5.00AH
Cyc:0027
```

- * Capacity:
- * RSOC: Rest of state of capacity
- * Remain: Remaining capacity
- * FCC: Full charge capacity
- * Cyc: Cycle times

* Temp(Temperature): Displays the temperature of all BMS probes

```

NTC1: 24.9°C   AirTemp: 25.8°C
NTC2: 23.4°C   PCBTemp: 25.0°C
NTC3: 23.4°C
NTC4: 23.6°C
  
```

* CellInfo(Cell Information): The units of cell voltage are all in millivolt

4.2.3.Pack Status

```

->Status:Protect
--Pro_Count   >>
--Pro_Status  >>
  
```

* Pro Count: Protection Count

* Pro Status: Protection Status

Item	Definition
OVP	Over Voltage Protection(single cell)
UVP	Under Voltage Protection(single cell)
POVP	Pack Over Voltage Protection
PUVP	Pack Under Voltage Protection
COTP	Charge Over Temperature Protection
CUTP	Charge Under Temperature Protection
DOTP	Discharge Over Temperature Protection
DUDP	Discharge Under Temperature Protection
COCP	Charge Over Current Protection
DOCP	Discharge Over Current Protection
SCP	Short Circuit Protection
LOCK	Soft Lock

4.2.4.Pack Parameters(Unfinished)

The item of this content is not settable.

4.2.5.Pack Settings

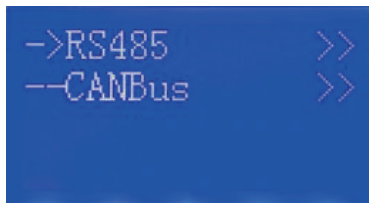

RS485: Set the BMS host RS485 interface protocol
CAN Bus: Set the CAN interface protocol of the BMS

Optional agreement content:

RS485	CAN BUS
RS485 - PYLON	CAN - Pylon
RS485 - GROWATT	CAN - VicTron
RS485 - Voltronic	CAN - GOODWE
RS485 - LXP	CAN - GROWATT
RS485 - DEYE	CAN - LXP
RS485 - INVT	CAN - DEYE
RS485 - SRNE	CAN - SOFAR
RS485 - OTHER	CAN - GINLONG
...	CAN - SMA
	CAN - MUST
	CAN - OTHER
	...

V. Lithium Battery IoT Cloud

5.1 Introduce

5.1.1. Home energy storage product support: Bluetooth local connection or WiFi (2.4GHz) network remote control.

5.1.2. Comprehensive data: Automatically calculate and summarize comprehensive information, such as SOC , voltage, current, PACK parallel number, cell voltage maximum and minimum values, cell temperature maximum and minimum values, inverter Protocol.

5.1.3. PACK data: switch to view each PACK data, such as S OC , SOH , voltage, current, capacity, number of cycles, charge and discharge status, number of cells, cell voltage, cell temperature, MOS temperature, ambient temperature, equilibrium state.

5.1.4. Parameter setting: Synchronize the comprehensive settings to PACK , or switch to each PACK to set parameters separately.

5.1.5. Device information: View the device information of each PACK , perform OTA upgrades on the PACK , and reconfigure the WiFi network.

Download the APP

Scan the QR code to download
the APP - JBD BMS



5.2 APP Use

Open the APP and the enter the interface. You can read basic battery information but nor have operation and parameter setting permissions.

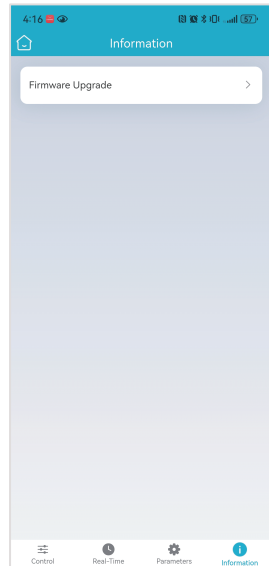
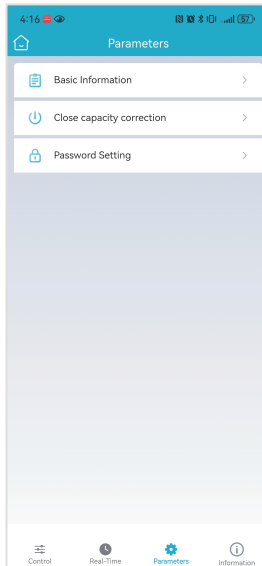
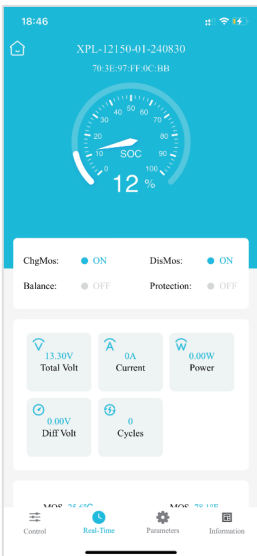
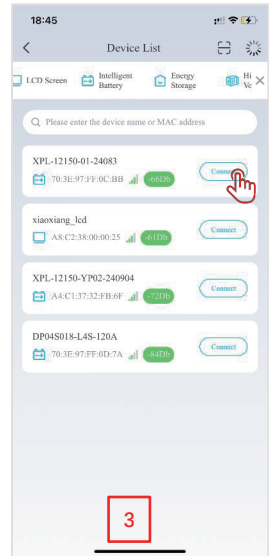
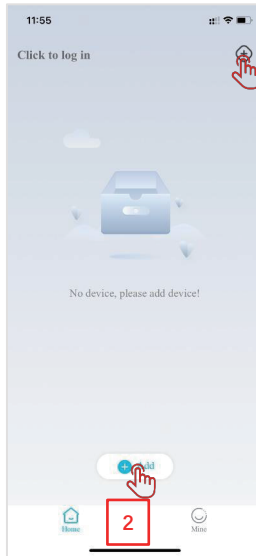
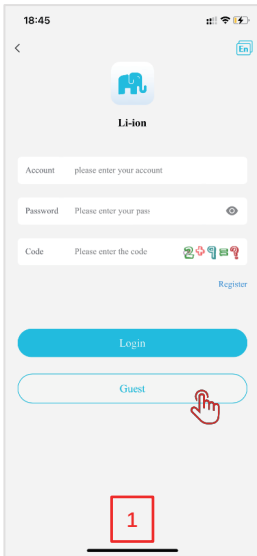

VI. Installation

6.1 Preparation

6.1.1 Safety Compliance

The system installation must be finished by qualified person(s), During the whole installation process, please strictly follow the local safety regulations and related operating procedures.

6.1.2 Environment

The operating environment shall meet the following requirements:

Category	Description
Working temperature	-20°C-55°C(maximum operating range) 15°C-30°C (optimal temperature)
Relative humidity	5%~90%, No condensation
Altitude	<3000m
Safety requirement	<ul style="list-style-type: none"> • Do not expose the battery to direct sunlight, rain and snow. • Do not place the battery within children/pet touchable area. • Do not place the battery near heat source and flammable material • Do not place the battery in a closed place where the ventilation is not available. • Do not drop, deform, impact, cut or spearing with a sharp object. • Do not put heavy things on battery. • Do not disassemble the battery without Manufacturer's permission. • No conductive dust and water or other liquid to contact battery. • Follow the emergency measure if there is water invasion or electrolyte and gas leakage. • Contact your supplier within 24 hours if any product failure happens.

6.1.3 Tools



Tools	
Screwdriver (slot, cross)	Multi-meter
Wrench	Clamp meters
Diagonal pliers	Insulating tape
Needle nose pliers	Thermometer (observe the installation environment)
Clamping pliers	Anti-static bracelet
Wire stripper	cable ties

6.2 Inspection

6.2.1 Unpack precautions

- * Please load and unload it in accordance with the specified requirements to prevent sun and rain when you receive the equipment.
- * Please check and confirm the goods (such as quantity, appearance, etc.) according to the "scope of delivery " before unpacking.
- * Do light take and put during unpacking process to protect the surface coating of the object;
- * Please record and contact to the manufacturer if the inner packing is damaged after unpacking.

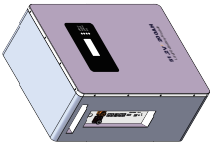
6.2.2 Scope of delivery

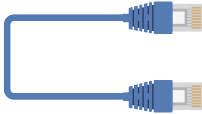
General materials		
 <p>Battery Pack *1pcs</p>	 <p>Manual *1pcs</p>	 <p>Communication cable *1pcs</p>

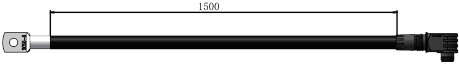
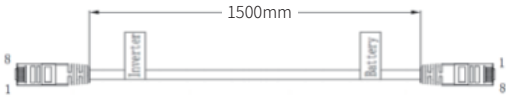
Type	Detail		Qty.	
Cables	A: Battery to Battery positive cable(3AWG 1500mm RED) 		1pcs	
	B: Battery to Battery negative cable(3AWG 1500mm BLACK) 		1pcs	
Communication cable (1 out of 3) (Packed with general materials)			1pcs	
	Version II(CAN):	Battery side pin		Inverter side pin
		Pin 4		Pin 7
		Pin 5		Pin 8
	Pin 6	Pin 3		
	Version III(RS485):	Pin 1	Pin 3	
		Pin 2	Pin 5	
Pin 3		Pin 8		

 **NOTICE**
 Keep the unused cable pins NULL to avoid affecting the closed loop communication.

 **NOTICE**
 A ground connection of communication cable may be required from some inverters, please follow the rules from inverter manufacture.

6.3 Start Installation

Qualified person

6.3.1 Remainder

Please check again the following conditions or equipment whether meet the requirements before installation:

- * Check if there's enough space for installation, and if the load-bearing capacity of the bracket or cabinet meets the weight requirements
- * Check whether the power cable pair(s) used meets the maximum current requirement for operation;
- * Check whether the overall layout of power supply equipment and batteries at the construction site is reasonable;
- * Check whether the installer is wearing anti-static wristband
- * Check whether there're two people on the construction site for installation work
- * Check if there's potential risks at location of installation site, e.g flooding, sun exposure, corrosion, and salt spray

6.3.2 Procedures



CAUTION

Injuries may result if the product is lifted incorrectly or dropped while being transported or mounted. Wear suitable personal protective equipment for all work on the product.



CAUTION

Ensure that no lines are laid in the wall which could be damaged when drilling holes.

6.3.2.1 Rack mounted

1. Take the battery pack out from carton.
2. Get the Rack ready and place it horizontally at a reasonable location.
3. Place the battery on the rack or cabinet tray via manual-lift. Insert the screws and fasten the battery to the rack or cabinet.
4. Finish the cable connection.

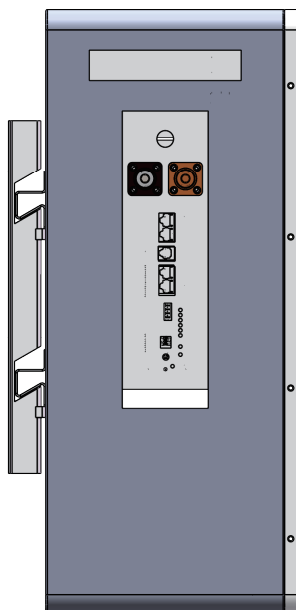

NOTICE

ANY others installations, please avoid the battery directly contacting the ground and avoid of high salinity, humidity to prevent the product from rusting and corrosion.

VII. Cable Connection and Commissioning

7. Cable connection and commissioning

Qualified person

7.1 Get battery ready

7.1.1 Ensure all the battery is in OFF mode, and confirm the installation is tighten and stable.

7.1.2 Check the number and specification of cable kit accessories are correct according to the Scope of delivery item, if you are making cable yourself, please follow manufacturer's requirements.

7.1.3 Switch on all battery individually, check whether there is any alarm/protection information, if yes, turns to troubleshooting. Then switch off all batter

7.2 Communication cable connection

7.2.1 Take out battery to battery communication cable.

7.2.2 Confirm the location of Master battery, insert the RJ45 plug into the Link Out port and connect the other side to next battery Link IN port, daisy chained all batteries.

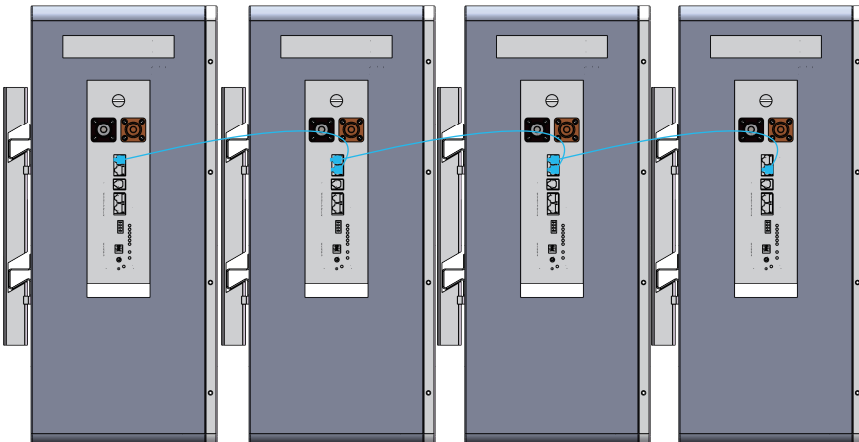

7.3 DC power cable connection

7.3.1 Take out battery to battery power cable.

7.3.2 Connect the positive and negative electrodes of the battery to the combiner box for parallel connection, and fix the battery terminals and combiner box with M8 screws

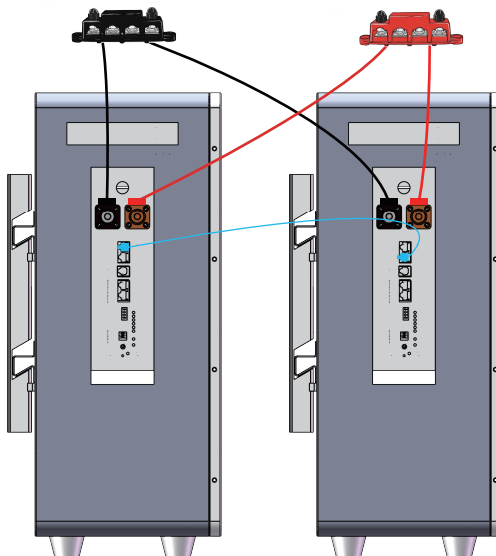

7.4 Connecting with inverter



CAUTION

Confirm inverter AC input and PV input is disconnected before wiring connection, and the DC/ signal switch of inverter/charger is in off status.

7.4.1 Connecting Master battery Link IN port with inverter CAN or RS485 communication port via inverter communication cable.

7.4.2 Connecting battery OUTPUT (+) with inverter battery INPUT (+), battery OUTPUT (-) with inverter battery INPUT (-), an external disconnection breaker between battery system and inverter is recommended, choose the corresponding power cable pair and wiring them correctly.

**NOTE**

Choose the suitable disconnection breaker considering the inverter power/current, rated voltage, tripping characteristic etc.

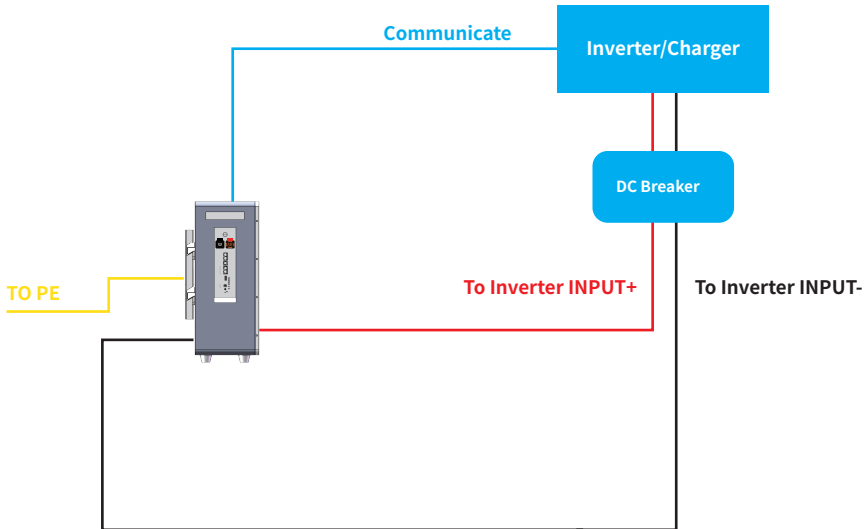
Wiring diagram allowed:**NOTICE**

The maximum communication cable length is required to be less than 15m between inverter/charge and battery.

The maximum power cable length is suggested to be less than 10m between inverter/charge and battery.

For other type of installation, please also follow the rules above to wiring your system.

**CAUTION**

The maximum tolerance current of each power cable and terminal is 125A, 100A for continuously is suggested, please use corresponding number of power cable pairs according to the field configuration and local connection requirements, standards, and directives.

7.5 Commissioning

7.5.1 Set the DIP address of the Master battery (and the Slave battery if there is any RS485 baud rate change).

7.5.2 Switch on all battery modules, wait 1 minute, and make sure that ON/OFF led is on Master battery.

7.5.3 Turn on the breaker between the inverter and battery if there is any, then turn on the inverter/charger isolator.

7.5.4 Finish the setting on inverter/charger or any other control devices. If everything is correct, you are ready to use the system.



CAUTION

If your system is an back-up or off-grid system, make sure your configuration can cover the worst situation to avoid battery to be over-discharged.

7.6 Switch off battery

7.6.1 Turn off the inverter.

7.6.2 Turn off the disconnection breaker if there is any.

7.6.3 Turn off all batteries power switch.

VIII.Troubleshooting

Items	Solution	Measure
Unable to start	<ol style="list-style-type: none"> 1. Switch on battery and press RESET 6s to observe whether the battery can be started. 2. Charge the battery use a charge or inverter to provide 54-57.6V voltage and observe it can be started. 	<p>If the abnormal status still alive after above steps, please contact your supplier.</p> <p>If there is any other situation(s) excluding in this table, turn off the fault battery, contact your supplier.</p>
Unable to charge	<ol style="list-style-type: none"> 1. Check whether the cable connection between the battery and the inverter/charger is correct. 2. Check whether the inverter/charger setting is correct. 3. Check whether the battery is in charge protection mode, if yes, try to discharge the battery. 	
Unable to discharge	<ol style="list-style-type: none"> 1. Check whether the cable connection between the battery and the inverter/charger is correct 2. Check whether the battery occurs short circuit, reverse connection, pre-charge failure during connection inverter etc. 3. Check whether the battery is in discharge protection mode, if yes, try to charge the battery. 	
High/Low temperature	<ol style="list-style-type: none"> 1. Stop the battery system for a while, check whether the installation location temperature meet the requirement. 2. Avoid continuous full charging and discharging 	
High current	Check the configuration and parameters setting on the inverter/charger is correct.	
ALM ON	Turn off all the batteries, and remove the fault battery from the system.	
Communication fail	<ol style="list-style-type: none"> 1. Check the communication cable type is correct and is contacted well. 2. Check the DIP switch setting is correct. 3. Check the inverter protocol related setting is correct. 4. Check both battery and inverter are working properly. 	



NOTICE

Please restart after software is upgraded.

IX. Transport and Storage

- * Do not violently shake, impact or squeeze, and prevent sun and rain during the transportation.
- * Do light take and put and strictly prevent falling, rolling, and heavy pressure during loading and unloading.
- * The battery should be placed in a dry, clean, dark, and well-ventilated indoor environment for long-term storage, and the recommended storage temperature range is 15~30°C .
- * No harmful gases, flammable and explosive products and corrosive chemical substances in the storage location.
- * The batteries should be stored and transported in close to 50% SOC, and do not store over 80% SOC for long time.
- * If do not use for a time, The battery needs to be charged every 6 months if it is not used for a long time.
- * No fall down, no pile up over 6 layers, and keep face up.

X. Disposal of battery

Disposal of battery must comply with the local applicable disposal regulations for electronic waste and used batteries, Please review your local Battery recycling or management regulations or contact us for more information.