

LiFePO4

51.2V 314AH LIFEP04 BATTERY MANUAL

Operation and Maintenance



SUPPORT

If you are experiencing technical problems and cannot find a solution in this manual, please contact for further assistance.



Description

This manual describes in detail the requirements and procedures for safe installation and operation of lithium battery pack. Please read this manual carefully. Only qualified persons are allowed to install, operate and maintain the system, otherwise it may cause product damage or personal safety risks.

Any actions against safety operation, or do not follow rules of this manual and limited warranty letter, will void warranty and qualification of this product. Meanwhile, the manufacturer will be not responsible for the product damage, property damage, personal injury or even death.

The information contained in this manual is accurate when it's issued. Reserves right to change specification (such as optimization, upgrade or other operations) without prior notice, and please always view the latest document via QR code on the label.

In addition, please noted that the diagrams/schematics in this document are used to help understand system configuration and installation instructions, which may be different from the actual items in the installation.

Contents

I.Information	1
1.1 Validity	1
1.2 Target Group	1
1.3 Levels of Warning Messages	1
1.4 Symbol Description	2
1.5 Abbreviation Description	3
II.Safety	4
2.1 Safety Precautions	4
2.2 Safety Instructions	4
2.2.1 Safety gear	5
2.2.2 Emergency safety measures	5
2.2.3 Other Tips	6
III.Product Overview	7
3.1 Introduction	7
3.2 Features	8
3.3 Specification	9
3.4 Buzzer Action Description	16
3.5 Button Description	17
3.6 Hibernation and Wake Up	17
3.7 Communication Description	18
IV.Display	19
4.1 Hibernation/Shutdown	24
4.2 Permission Specification	24
4.3 Installation and Use	24
4.4 Parts List	24

V. Lithium Battery IoT Cloud	25
5.1 Download and Install.....	25
5.2 APP Dynamic Permission.....	25
5.3 Control Method	26
5.4 Local Control(BLE).....	26
5.5 Telecontrol	27
VI.Installation	36
6.1 Preparation	36
6.1.1 Safety Compliance	36
6.1.2 Environment.....	36
6.1.3 Tools	37
6.2 Inspection	37
6.2.1 Unpack precautions	37
6.2.2 Scope of delivery	37
6.3 Start Installation	39
6.3.1 Reminder	39
6.3.2 Procedures.....	39
VII.Cable Connection and Commissioning	41
7.1 Get Battery Ready.....	41
7.2 Communication Cable Connection	41
7.3 DC Power Cable Connection	42
7.4 Connecting With Inverter.....	42
7.5 Adaptation inverter list	44
7.6 Commissioning	45
7.7 Switch off Battery	45
VIII.Troubleshooting	46
IX.Transport and Storage	47
X.Disposal of Battery	47

I. Information

1.1 Validity

This document is valid for: **LFP-51.2V 314AH**

1.2 Target Group

This document is intended for qualified persons and operators. Only qualified persons are allowed to perform activities marked with a warning symbol and the caption "Qualified person" in this document. Qualified persons must have the following skills:

- * Knowledge of how lithium iron phosphate batteries work and are operated.
- * Knowledge of how an energy storage system (including PV/battery/hybrid inverter, MPPT, Meter, Distribution box etc.) works and is operated.
- * Knowledge of local applicable connection requirements, standards, and directives.
- * Training in the installation and commissioning of electrical devices, batteries.
- * Training in how to deal with the dangers and risks associated with installing, repairing and using electrical devices and batteries.

1.3 Levels of Warning Messages

The following levels of warning messages may occur when handling the product.



DANGER

Indicates a hazardous situation which, if not avoided, will result in death or serious injury.



WARNING

Indicates a hazardous situation which, if not avoided, could result in death or serious injury.



CAUTION

Indicates a hazardous situation which, if not avoided, could result in minor or moderate injury or product permanent damage.



NOTICE



Indicates a situation which, if not avoided, can result in property damage or product not work or accelerated product damage.

1.4 Symbol Description

1.4.1 Symbols on products label

Symbols	Definition
	Indicates the danger of electric shock. If not avoided, it would cause casualties.
	Indicates a potentially dangerous condition which could result in injury or death.
	Indicates important information or warnings related to concepts talked about in the text.
	Indicates more information is available in other documents relating to the subject and reader.
	Indicates important steps or tips for optimal performance.
	Do not place the battery within children/pet touchable area.
	Do not place the battery near heat source and flammable material.
	Do not expose the battery to direct sunlight, rain and snow.
	Do not short circuit the battery.
	Recycle label
	WEEE designation

1.4.2 Other symbols

Label	Definition
 Qualified person	Indicates activities that can only be performed by qualified persons
	Grounding point

1.5 Abbreviation Description

Abbreviation	Definition
Battery/battery pack/battery module	Single LFP-51.2V 314AH rechargeable lithium rechargeable lithium iron phosphate battery pack including cells, BMS and enclosure etc.
Battery system/ cluster	Multiple LFP-51.2V 314AH battery pack connected in parallel with power, communication and grounding cables and installation auxiliaries.
BMS	Battery management system Electronical Unit to ensure lithium cells' safety and display information or control the battery work mode.
SOC	State of charge The battery state of charge refers to the percentage of the remaining capacity and rated capacity of the battery.
SOH	State of health The battery health status refers to the percentage between the full charged capacity and the rated capacity of the battery.
DIP switch	Dual in-line package switch

II. Safety

2.1 Safety Precautions



DANGER

- Do not impact the battery with heavy objects.
- Do not squeeze or pierce the battery pack.
- Do not throw the battery pack into the fire.



WARNING

Fire risk

- Do not expose the battery pack to the condition over 80°C.
- Do not put the battery near a heat source, such as a fireplace.
- Do not expose the battery pack to direct sunlight or raining.



WARNING

Electric shock risk

- Do not allow non-qualified person to disassemble the battery pack.
- Do not touch the battery pack with wet hands.
- Do not expose the battery pack to moisture or liquid environment.



NOTICE

Damage risk

- Do not short-circuit or reverse connect the battery.
- Do not use chargers or charging devices unapproved by the manufacturer to charge the battery.
- Do not mix batteries from different manufacturers or different kinds, types or brands.

2.2 Safety Instructions

The battery has been designed and tested in accordance with international (such as UL, IEC, UN38.3 etc.) safety requirements. However, Due to various factors during the whole lifetime process, we cannot guarantee absolute safety, in order to prevent personal injury and property damage and ensure long-term operation of the battery, please do read and following the below section carefully to operate the battery and handle emergency situations.

2.2.1 Safety gear

It is required to wear the following safety gear when installing and handling the battery pack.



2.2.2 Emergency safety measures

* Water invasion

Please cut off the AC power supply of the system first and then disconnect all switches under the premise of ensuring safety.

* Electrolyte or gas leakage

If the battery pack leaks electrolyte, avoid contact with the leaking liquid or gas. If one is exposed to the leaked substance, immediately perform the actions described below.

·Gas Inhalation: Evacuate the people from the contaminated area and seek medical aid immediately.

·Eye Contact: Flush your eye with clean and flowing water for 15 min, and then seek medical aid immediately.

·Skin Contact: Thoroughly rinse the exposed area with soap and water to be sure no chemical or soap is left on them, and seek medical aid immediately.

·Ingestion: Induce vomiting, and seek medical help immediately.



WARNING

In case of fire situations, please use carbon dioxide fire extinguisher rather than liquid to put out fires.

2.2.3 Other Tips

·All the product are strictly inspected before shipment, Please contact us for replacement if you notice there are any defectives such as swelling etc.

·Do not disassemble batteries and components, otherwise the manufacturer will not be responsible for any damage caused by unauthorized disassembly or repair.

·Enable the battery to be safely grounded before use to make sure the system in safe and normal operation.

·Please ensure that the electric parameters of these devices are compatible mutually before connecting the battery to other devices.

·Please take the environmental factors into careful considerations to ensure that the system can work in a suitable condition as the environment and storage methods have a certain impact on the service life and reliability of this product.

III.Product Overview

3.1 Introduction

The LFP-51.2V 314AH battery is designed for residential application and works as a storage unit in the photovoltaic system. It is a 48V Li-ion battery storage system, with BMS inside itself. It could be operated in both on-grid, back-up and off-grid modes with compatible inverters. Below is the general schematic of an ac-coupled system.

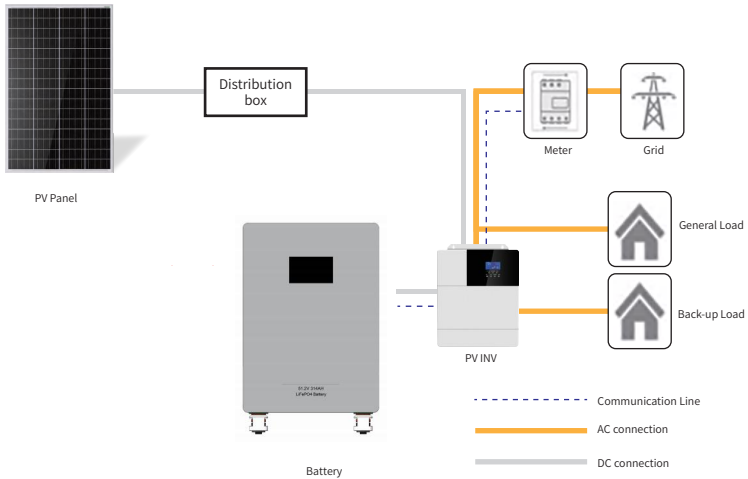

This electrical connection in this diagram is only for illustration, please follow the Manual suggestions of related devices and operate in accordance with locally applicable connection requirements, standards, and directives.

3.2 Features

- Highest safety, battery is made from LiFePO₄ chemistry and comply with highest international safety and transport standard.
- Modular and flexible, support up to 15 batteries connect together to expand the system energy.
- Build-in pre-charge circuit to avoid rush current when connecting with different inverter/chargers.
- Automatic dynamic addressing function when connected multiple batteries together.
- Rapid shutdown function for North American market.
- Support a maximum of 96% DOD under off-grid and back-up application
- Built in BMS provide warning and protection functions including over-discharged, over-charged, over-current, short-circuit and high/low temperature.
- LiFePO₄ as cathode material and automatic balancing function to meet long cycle life
- Compact size and light weight for easy installation and maintenance.
- CAN/RS485 port for external communication and upgrade the BMS firmware.

3.3 Specification

3.3.1 Dimension

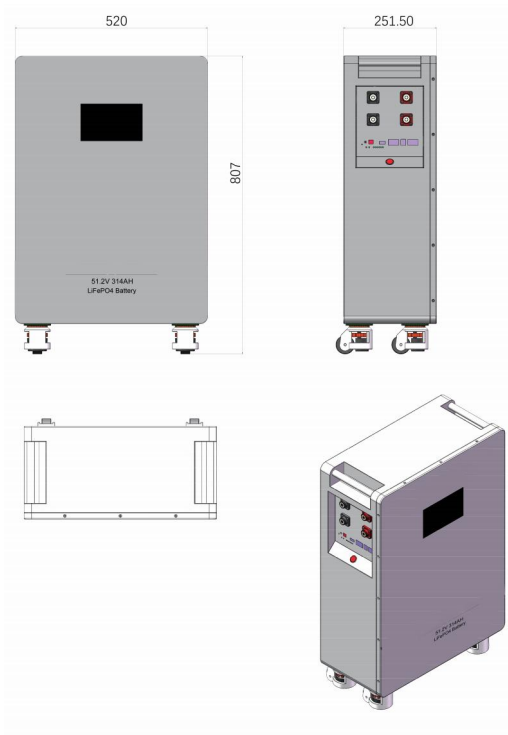

3.3.2 Parameters

Items	LFP-51.2V 314AH
Nominal voltage	51.2V
Voltage range	40~58.4V
Max. charge voltage	58.4V
Charge cut-off voltage	40.0V
Nominal energy	16.08kWh
Usable energy	16.08kWh
Nominal capacity	314Ah

Dimension	31.77*20.47*9.92in/80.7*52.0*25.2cm	
Weight	286.6lb/130kg	
Standard charge current	100A	
Max. charge current	200A	
Standard discharge current	≤150A	
Max. discharge current	200A(initial temp. ≤35°C)	
Communication	RS232 /CAN/RS485	
Max. parallel number	15pcs	
Operating temperature	Charge: 0~65°C Discharge:-20~65°C	
Storage temperature	-20~25°C	Less than 1 year
	20~40°C	less than 3 months
	Environment at the shipment state	60±25%R.H.



NOTICE
 The optimum operating temperature range is from 15°C to 30°C, Frequent exposure to the harsh temperatures may worsen the performance of the battery pack and cycle life.

3.3.3 Panel Interface

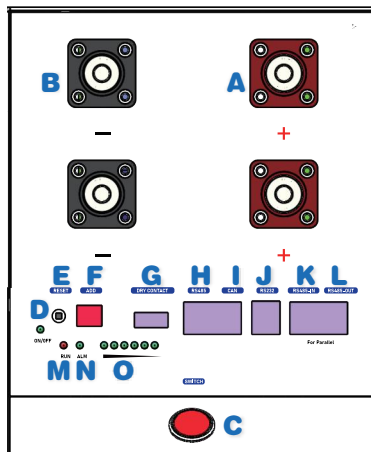

NO.	Items	Usage description	Remark
A	Positive terminal	Used to connect the inverter/charger	
B	Negative terminal	Used to connect the inverter/charger	
C	Power switch	Used to Power on/off battery	
D	ON/OFF indicator	Indicates whether the battery is turned on or off	
E	Reset	Used to reset the BMS	
F	ADD	Used to set the RS485 baud rate and inverter protocol choosing	
G	Dry contact	2 channels output signal 1 channel input signal	Pin1 on the left
H	RS485-1	Connect to host computer/inverter	
I	CAN	Connect to host inverter	
J	RS232	Host computer communication interface	
K	RS485 IN	For communication between batteries	
L	RS485 OUT	For communication between batteries	
M	RUN	Used to show battery is in running status when lighting or flashing	
N	ALM	Used to show battery Alarm/Protection status	
O	SOC	Used to show battery real-time SOC	

3.3.3.1 F: ADD



When PACKs are used in parallel, different PACKs can be distinguished by setting the address through the dip switch on the BMS. It is necessary to avoid setting the address to the same. The definition of the BMS dip switch refers to the table below. In parallel mode, the default dip address 1 is the host.

ADD	Dial switch position			
	1	2	3	4
1	ON	OFF	OFF	OFF
2	OFF	ON	OFF	OFF
3	ON	ON	OFF	OFF
4	OFF	OFF	ON	OFF
5	ON	OFF	ON	OFF
6	OFF	ON	ON	OFF
7	ON	ON	ON	OFF
8	OFF	OFF	OFF	ON
9	ON	OFF	OFF	ON
10	OFF	ON	OFF	ON
11	ON	ON	OFF	ON
12	OFF	OFF	ON	ON
13	ON	OFF	ON	ON
14	OFF	ON	ON	ON
15	ON	ON	ON	ON



NOTICE

Fail to follow the DIP switch setting will cause the communication fault between battery and inverter, for more detail setting with different inverter/charger, please contact your supplier or us for consultation.

3.3.3.2 Introduction to Communication Interface



1 2 3 4

(Dry Contact)

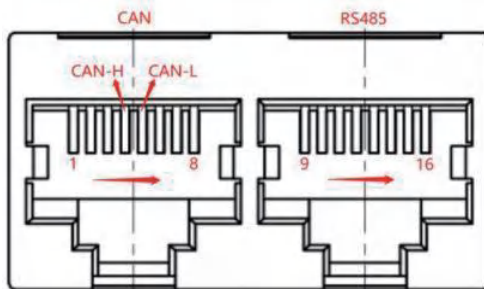

CAN--Adopting 8P8C vertical RJ45 socket		RS485--Adopting 8P8C vertical RJ45 socket	
RJ45 Pin	Definition Explanation	RJ45 Pin	Definition Explanation
1、3、6、7、8	NC	9、16	RS485-B1
4	CAN-H	10、15	RS485-A1
5	CAN-L	11、14	GND
2	GND	12、13	NC

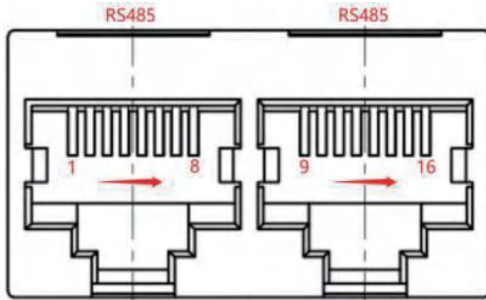



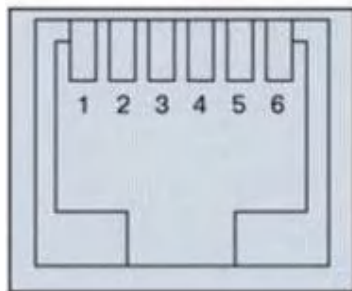





RS485--Adopting 8P8C vertical RJ45 socket		RS485--Adopting 8P8C vertical RJ45 socket	
RJ45 Pin	Definition Explanation	RJ45 Pin	Definition Explanation
1、 8	RS485-B	9、 16	RS485-B
2、 7	RS485-A	10、 15	RS485-A
3、 6	GND	11、 14	GND
4、 5	NC	12、 13	NC



RS232- using 6P6C vertical RJ11 socket	
RJ11 Pin	Definition Explanation
1、 2、 6	NC
3	TX (single board)
4	RX (single board)
5	GND

3.3.3.4 LED Display Description

LED working status indication

STATE	Normal/Warning / Protection	ON/OFF 	RUN 	ALM 	Battery indicator LED						EXPLANATION
					L6	L5	L4	L3	L2	L1	
											
Shutdown	Hibernation	OFF	OFF	OFF	OFF	OFF	OFF	OFF	OFF	OFF	All OFF
Standby	normal	ON	Flash 1	OFF	According to the power indicator						Standby mode
	Alerts	ON	Flash 1	Flash 3							Module low voltage
Charge	normal	ON	ON	OFF	According to the power indicator (Power indicator LED Flash 2)						The highest power LED flashes (2 flashes) , ALM does not flash when charging alarm occurs
	Alerts	ON	ON	Flash 3							
	Overcharge protection	ON	ON	OFF	ON	ON	ON	ON	ON	ON	If there is no mains power, the indicator light turns to standby mode
	Temperature, overcurrent, failure Protect	ON	OFF	ON	OFF	OFF	OFF	OFF	OFF	OFF	Stop charging
Discharge	normal	ON	Flash 3	OFF	According to the power indicator						
	Alerts	ON	Flash 3	Flash 3							
	Undervoltage protection	ON	OFF	OFF	OFF	OFF	OFF	OFF	OFF	OFF	Stop discharge
	Temperature, over current, short circuit, Reverse connection, failure protection	ON	OFF	ON	OFF	OFF	OFF	OFF	OFF	OFF	Stop discharge
Invalidation		OFF	OFF	ON	OFF	OFF	OFF	OFF	OFF	OFF	Stop charging and discharging

Capacity Indicator

STATE		CHARGE						DISCHARGE					
Capacity indicator light		L6	L5	L4	L3	L2	L1	L6	L5	L4	L3	L2	L1
		●	●	●	●	●	●	●	●	●	●	●	●
Battery capacity (%)	0%~17%	OFF	OFF	OFF	OFF	OFF	Flash 2	OFF	OFF	OFF	OFF	OFF	ON
	18%~33%	OFF	OFF	OFF	OFF	Flash 2	ON	OFF	OFF	OFF	OFF	ON	ON
	34%~50%	OFF	OFF	OFF	Flash 2	ON	ON	OFF	OFF	OFF	ON	ON	ON
	51%~66%	OFF	OFF	Flash 2	ON	ON	ON	OFF	OFF	ON	ON	ON	ON
	67%~83%	OFF	Flash 2	ON	ON	ON	ON	OFF	ON	ON	ON	ON	ON
	84%~100%	Flash 2	ON	ON	ON	ON	ON	ON	ON	ON	ON	ON	ON
Running indicator light ●		ON						Flash (Flash 3)					

LED Flashing Description

Flashing mode	Bright	Destroy
Flash 1	0.25S	3.75S
Flash 2	0.5S	0.5S
Flash 3	0.5S	1.5S

3.4 Buzzer Action Description

In case of fault, it beeps for 0.25S every 1S;

In case of protection, it beeps for 0.25S every 2S (except overvoltage protection); In case of alarm, it beeps for 0.25S every 3S (except overvoltage alarm);

The buzzer function can be enabled or disabled by the host computer, and is disabled by factory default.

3.5 Button Description

When the BMS is in Hibernation mode, press the button (3~6S) and release it, the protection board is activated, and the LED indicators light up for 0.5 seconds starting from "RUN".

When the BMS is in active mode, press the button (3~6S) and release it, the protection board is in Hibernation mode, and the LED indicators light up for 0.5 seconds starting from the lowest power indicator.

When the BMS is in active mode, press the button (6~10S) and release it, the protection board is reset, and all LED indicators light up for 1.5 seconds at the same time.

After the BMS is reset, the parameters and functions set by the host computer are still retained. If you need to restore to the initial parameters, you can use the "Restore Defaults" of the host computer to achieve this, but the relevant operation records and storage data remain unchanged (such as power, number of cycles, protection records, etc.).

3.6 Hibernation and Wake Up

3.6.1 Hibernation

When any of the following conditions are met, the system enters low power mode:

- 1) Single or overall over-discharge protection is not released within 30 seconds.
- 2) Press the button (3~6S) and release it.
- 3) The lowest single voltage is lower than the sleep voltage, and the duration reaches the sleep delay time (no communication, no protection, no balance, no current).
- 4) The standby time exceeds 24 hours (no communication, no charging and discharging, no mains power).
- 5) Force shutdown through the host computer software.

Before entering sleep mode, make sure that the input terminal is not connected to external voltage, otherwise it will not be able to enter low power mode.

3.6.2 Wake up

When the system is in low power mode, if any of the following conditions are met, the system will exit low power mode and enter normal operation mode:

- 1) Connect to a charger, and the charger output voltage must be greater than 48V.
- 2) Press the button (3~6S), and then release the button.
- 3) RS232 is activated.

3.7 Communication Description

3.7.1 RS232 Communication

BMS can communicate with the host computer through the RS232 interface, so that the host computer can monitor various battery information, including battery voltage, current, temperature, status and battery production information, etc. The default baud rate is 9600bps.

3.7.2 CAN Communication

The default baud rate is 500K. This interface is used to communicate with the inverter. When this battery is the host, it can summarize the slave data and communicate with the inverter.

3.7.3 Parallel RS485 Communication

You can view the information of PACK, the default baud rate is 9600bps. If you need to communicate with the monitoring device via RS485, the monitoring device acts as the host and polls data according to the address. The address setting range is 2~15.

3.7.4 Independent RS485 Communication

The default baud rate is 9600bps. This interface is used to communicate with the inverter. When this battery is the host, it can summarize the slave data and communicate with the inverter.



CAUTION

Please re-charge the battery via solar, grid/generator or other energy source within 24h if the battery is over discharged.



NOTICE

Manually short-circuit and reverse the battery will void the warranty.

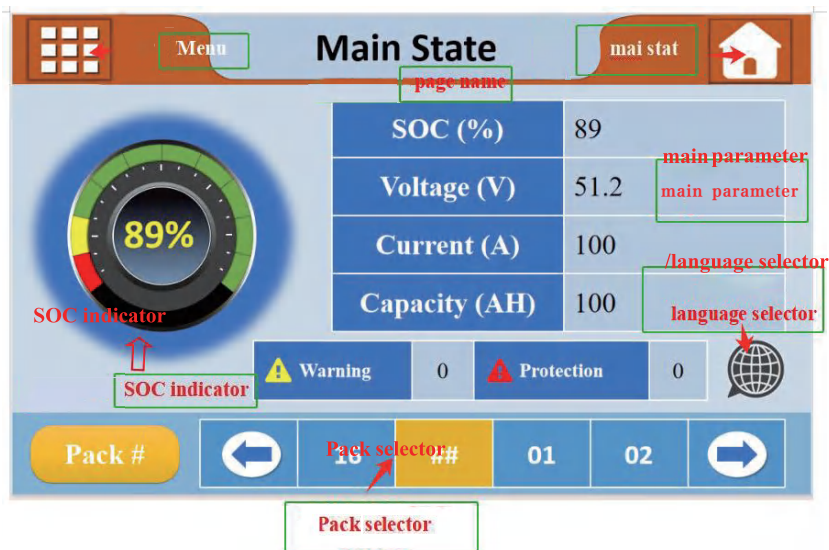

IV.Display

➤ Main state page



Note: After 3 seconds of the startup welcome interface, it will automatically enter this interface; any time, automatically enter this interface after waking up from the screen;

Icon Description

	Main menu icon, click to enter the main menu interface
	Main state icon, click to enter the Main State interface
	System Settings/Language Selection

> Menu Page

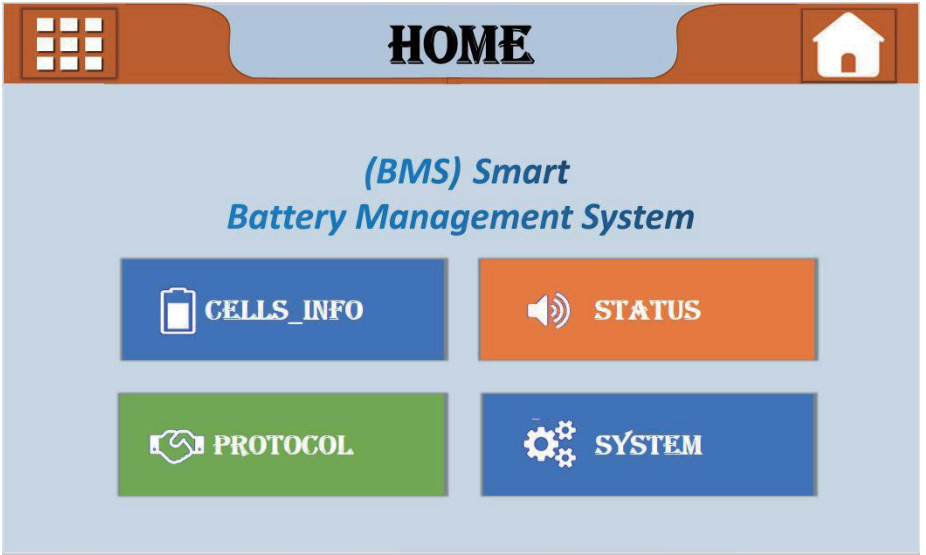

> (Cells info)

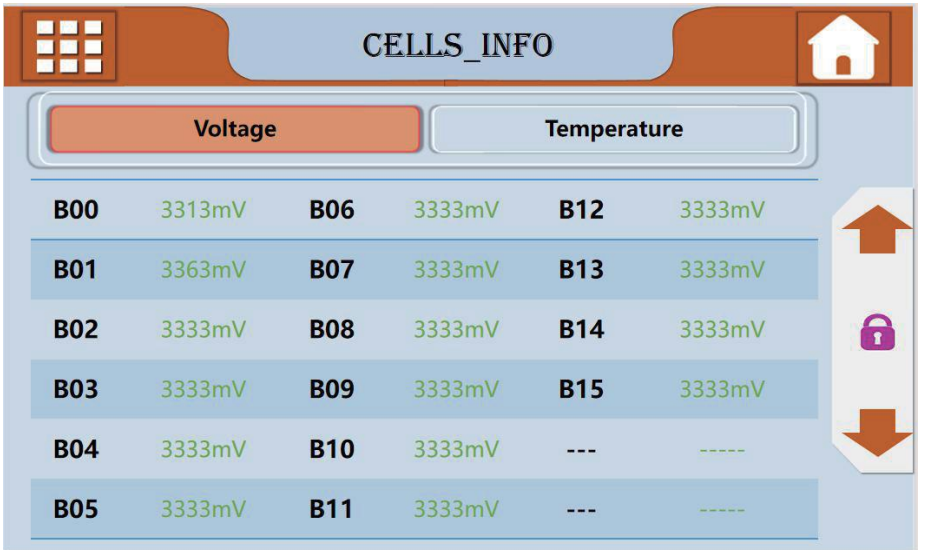

CELLS_INFO
Home

Voltage
Temperature

Mos_T	33°C	ENV_T	33°C	T11	--
T01	33°C	T06	--	T12	--
T02	33°C	T07	--	T13	--
T03	33°C	T08	--	T14	--
T04	33°C	T09	--	T15	--
T05	33°C	T10	--	T16	--

↑
↓

🔒

➤ (Protocol page)

PROTOCOL
Home

RS485
CAN

※ 已经设置的485 PROTOCOL (默认)

1、485 PROTOCOL 07
2、485 PROTOCOL 08
3、485 PROTOCOL 09
4、485 PROTOCOL 10
5、485 PROTOCOL 11
6、485 PROTOCOL 12

↑
↓

🔒

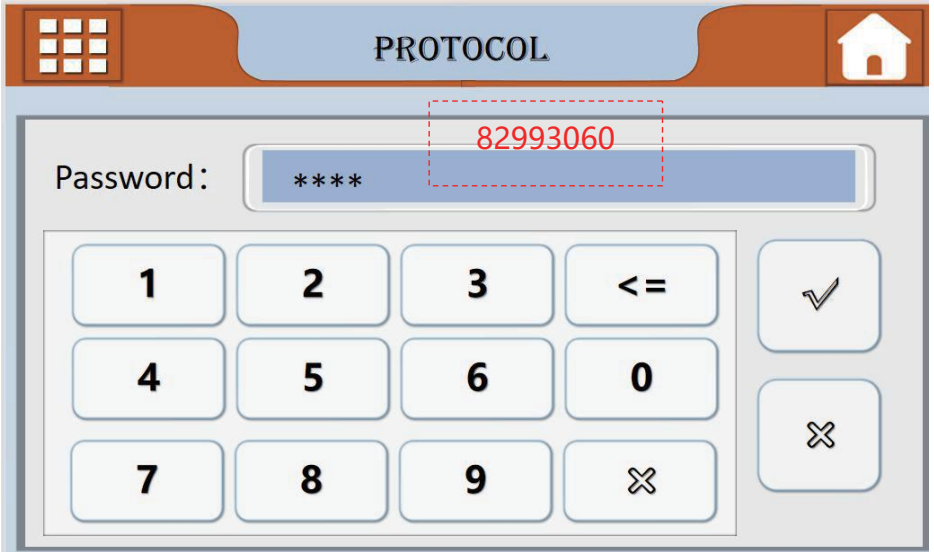

Note: Built in unlock password 82993060; Exit the protocol interface, the permission is invalid, modify the protocol again, and the permission needs to be verified again.

➤ (system page)



-
- Welcome interface (power on for 3 seconds, enter the main status interface)
- Min state page
 - ❖ SOC(Total)
 - ❖ Current
 - ❖ Voltage
 - ❖ Warning
 - ❖ Protection
 - ❖ Pack selector
 - ❖
 - Language selection icon, linked to [System Settings]
- HOME (Menu)
 - ❖ Cells Info (pack)
 - ◆ Voltage
 - Cell01 voltage
 - Cell02 voltage
 -
 - Cell16 voltage
 - ◆ Temperature
 - NT1
 - NT2
 - NT3
 - NT4
 - Mos_T
 - ENV_T
 -
 - ❖ BMS Status
 - ❖ Warning/Protect/Fault
- PROTOCOL
 - ◆ CAN
 - GOOD WE PROTOCOL
 - LV BMS Protocol(CAN) for Solar Inverter Family EN_V 1.5
 - PYLON PROTOCOL 2.0
 - Pylon CAN bus protocol V 2.0.420211122
 - SMA PROTOCOL
 - SMAFSS-Connecting Bat-TI-en-20W
 - GROW ATT_PROTOCOL
 - Growatt BMS CAN-Bus-protocol-low-voltage
 - ◆ RS485
 - USER_485_VOLTRON
 - Voltronic Inverter and BMS 485 communication protocol 20200325(1)
 - PYLON
 - RS485-protocol-pylon-low-voltag
 - Luxpowertek Battery Protocol RS 485_V 01
 - ❖ SYSTEM
 - ◆ Language select
 - (English, Chinese, Traditional Chinese, Russian, etc)
 - ◆ System No.
 - PACK SN
 - Product model
 - BLUETOOTH SN

4.1 Hibernation/Shutdown

In normal operating mode, after 3 minutes of no button operation, the system will enter sleep/shutdown mode. In the shutdown/sleep mode, clicking on any position on the color screen will activate the display screen and enter the main status interface. At the same time, the authorization will be reset to zero.

4.2 Permission Specification

Permissions are divided into three levels:

No permission: you can browse the welcome interface, main status interface; Restrict the browsing of other cell details and fault alarm details;

Operator rights: can browse all interfaces, can choose language options, can not set and modify the protocol;

Administrator rights: you can browse all interfaces, you can choose language options, you can set and modify the cooperation;

Protocol permission security: re-enter the protocol setting interface need to re-enter the administrator password, exit the protocol interface entered password will be cleared;

Password: administrator password, 82993060, operator password, 87654321.

4.3 Installation and Use

Please connect the display screen to the main control board through a dedicated ribbon cable!

4.4 Parts List

NO.	NAME	MODEL	QTY
1	DISPLAY BOARD	CTP70H-30629-1.5	1PCS
2	I/O BOARD	IOB-30771-1.0	1PCS
3	wire	4P(2.5X)-500mm-4P(2.5S)-1.0	1PCS
4	wire	4P-500mm-4P-2.0S-1.0	1PCS

V.Lithium Battery IoT Cloud

5.1 Download and Install

According to the mobile phone system, select the download link:

Android entrance: Mobile phones that support GMS can download PACEEX App through Google Play Store, and Android phones that do not support GMS can install APK directly.

<https://play.google.com/store/apps/details?id=com.paicheng.bms>

iOS entrance: Search for PACEEX downloads in the App Store

<https://apps.apple.com/cn/app/6461723294>

5.2 APP Dynamic Permission

Install the APP, click the start button and start smoothly. For the first start, you will request the user to confirm and authorize the following authority: Camera permission: Add wifi devices in remote control Location permission: search for nearby Bluetooth devices in local control and identify current network information in remote control Equipment status information: to detect the operation status of the equipment Photos and audio: The code scanning interface in the remote control system can directly identify the local photo album

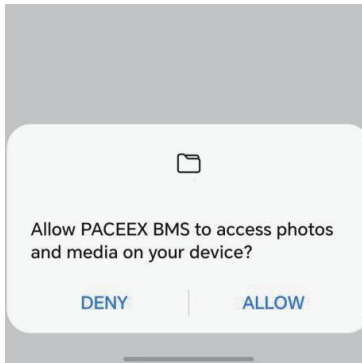
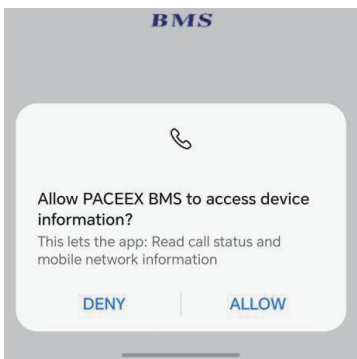
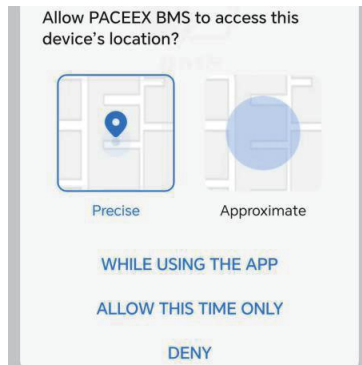
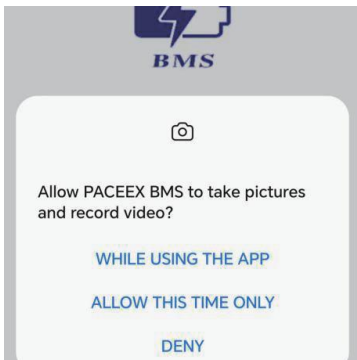

5.3 Control Method

Local control: BLE Bluetooth communication, directly search for the nearby Bluetooth signal, a pair of continuous connection, control devices, no account login, do not do binding records, that is, ready to use Remote-control:

WiFi communication, which realizes the purpose of controlling the device rather than in the same geographical location. It requires account registration and login, records the binding between the account and the device, and requires distribution network operation.



5.4 Local Control(BLE)

When the device is in the distribution network state, click the local control button to search the device on the local control page, and click the device to enter the device control page

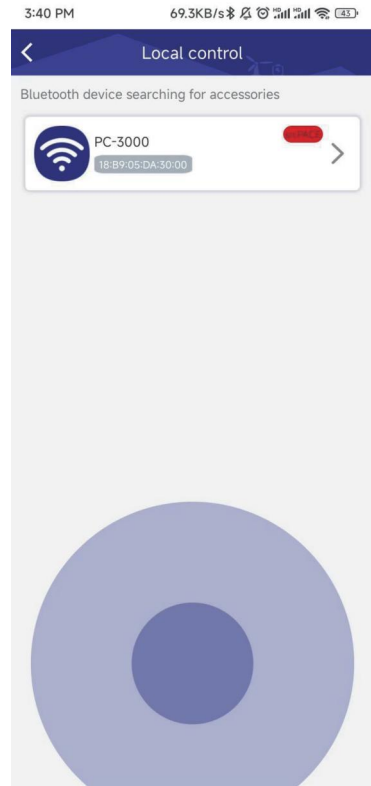

5.5 Telecontrol

5.5.1 Account registration and login

Registration: Create the new account by means of email account, password and verification code. Note: Please select the real country and region according to the actual situation. This is very important. Once selected and created successfully, the devices added through the account distribution network will automatically connect to the server node with the same account

Login: Log in with the registered account number and password

Forget your password: You can reset your password through your email number

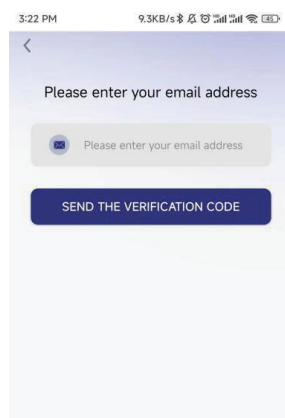
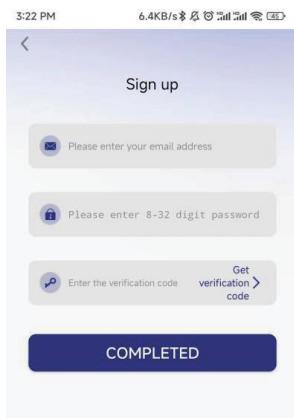
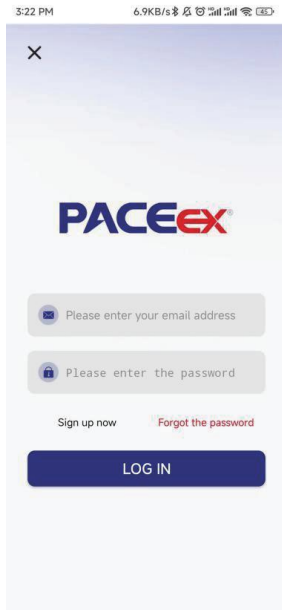

5.5.2 List of equipment

5.5.3 Equipment added

The wifi module is put back in the factory The wifi module restores the factory so that the device is in a discoverable state :

Long press the reset button 10-13 s, the specific operation of the LED lamp is shown as : long press the button to make the water lamp run one.



5.5.4 Click "Add" and "+" to enter the search page and search for the device

Note: This step requires the phone to open the "Bluetooth", "Positioning" and "WiFi" functions, otherwise the search and subsequent distribution network operation cannot be completed

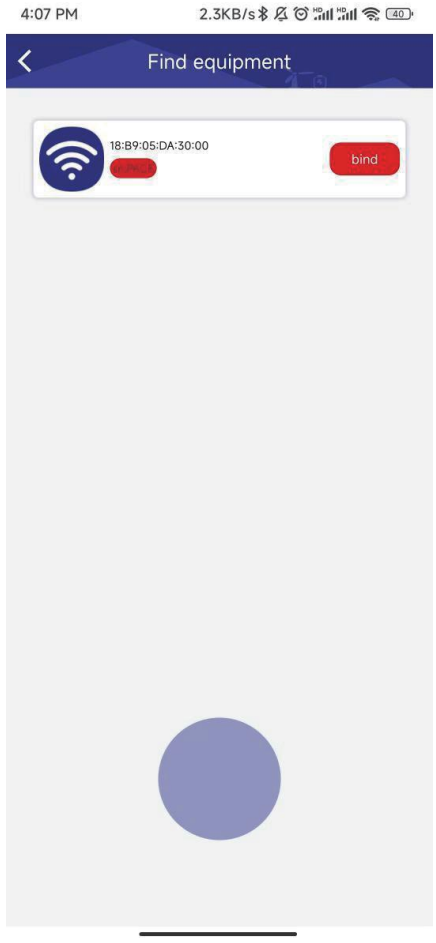
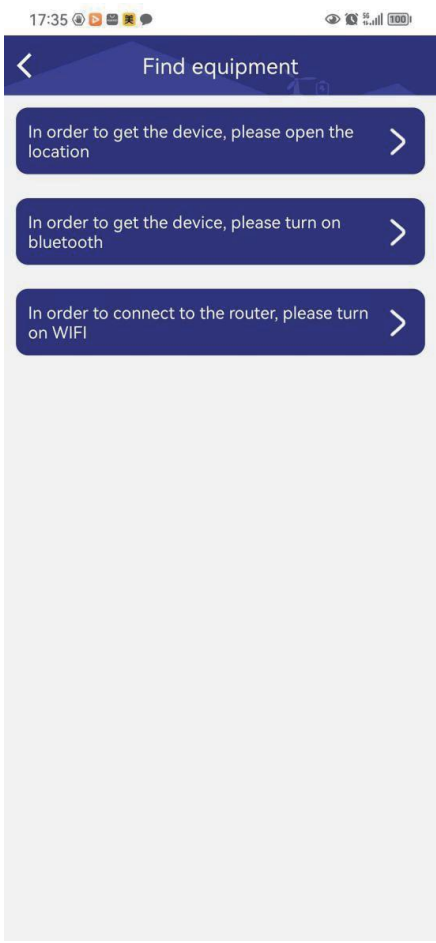

5.5.5 Fill in the distribution network information

Click the device found in 5.3.2, jump to the distribution network information page, fill in the WiFi account and password of the device to be connected, or change the WiFi. After confirming that the password is correct, click "Next" to enter the distribution network waiting page
Note: The mobile phone should be connected to the WiFi first, and the module only supports 2.4G WiFi, please identify it by yourself

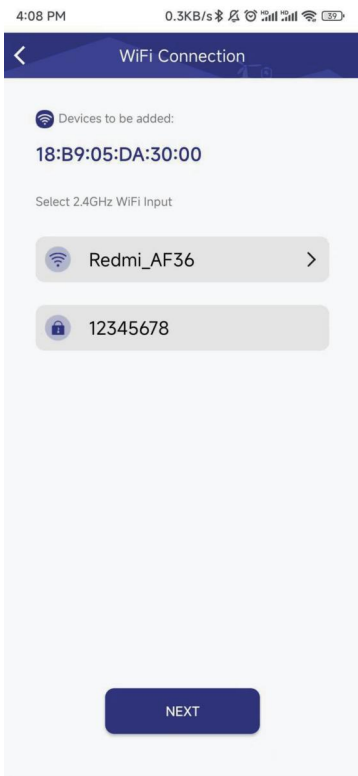

5.5.6: Execute distribution network operation

APP and device will automatically perform "Connect device", "Configure network", "device cloud" and "bind device" operations. Please wait patiently

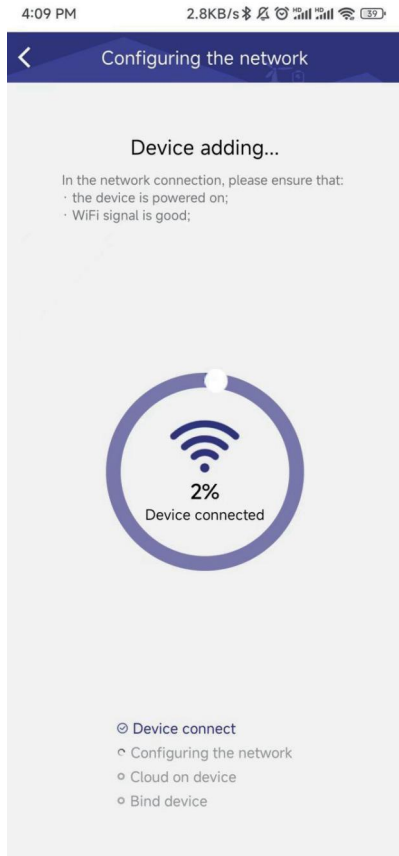

5.5.7 Distribution network results

When the distribution network is over, it will jump to the page, click Save to successfully add and automatically jump back to the device list page; If the network fails, please follow the prompts of the APP, and start from step 5.3.1 after inspection. If the network still fails for many times, please save the error page and contact the after-sales personnel!

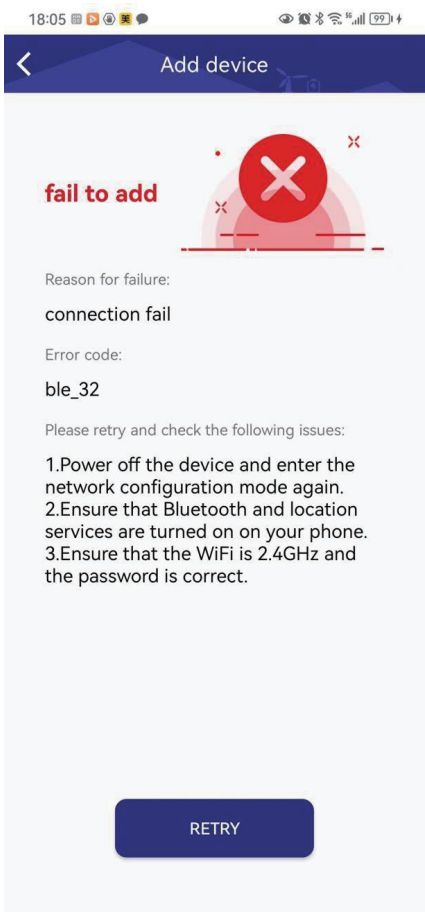
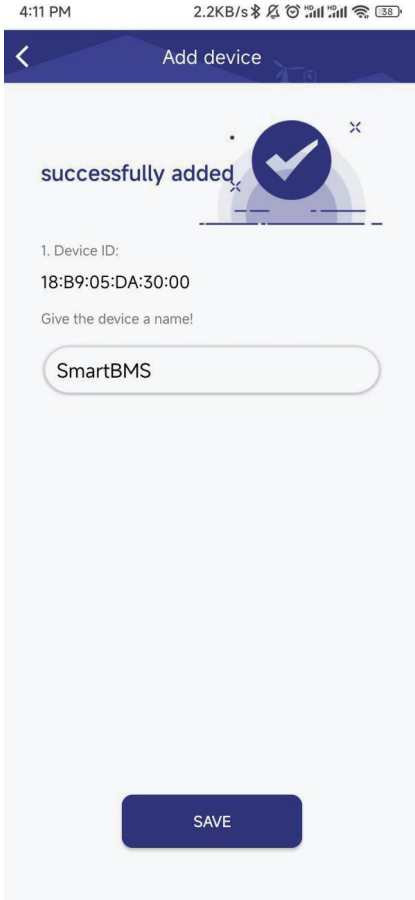

5.5.8 Device editor

Long press the device item, and the edit menu will pop up at the bottom
Rename: Modify device nickname to use Delete: unbinding with the device, the next use need to scan the code or add the network

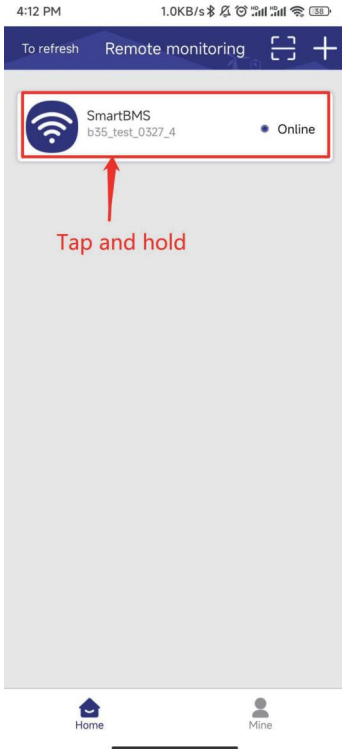

5.5.9: Device sharing

Long press the device item, when you are the device administrator (the first account bound to the first distribution network), the device can generate a QR code for other users to scan the code to add.

Note: Non-administrators cannot share twice. The QR code generated each time can only be scanned once, and the time of scanning the code is limited (30 minutes).

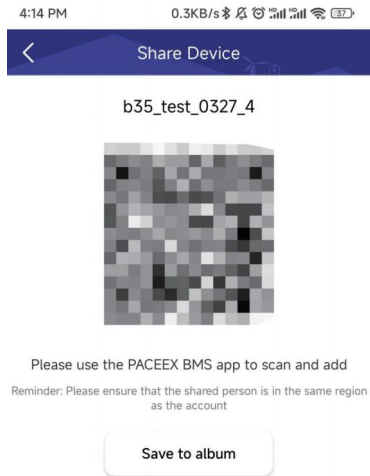

5.5.10 Device control

According to the functions supported by serial port protocol 0.0.9, except for the protocol itself, the summary interface, basic data, voltage and temperature, state data, historical data, parameter setting, equipment information, general setting, etc

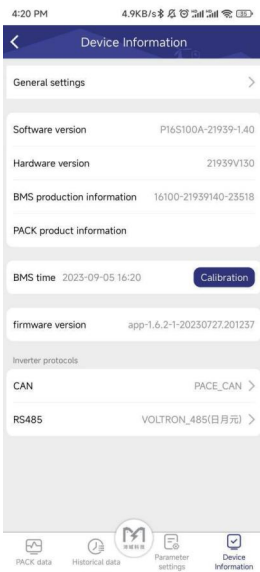
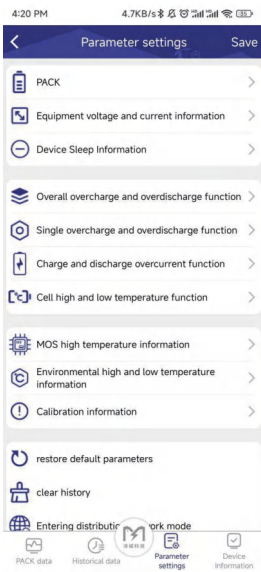
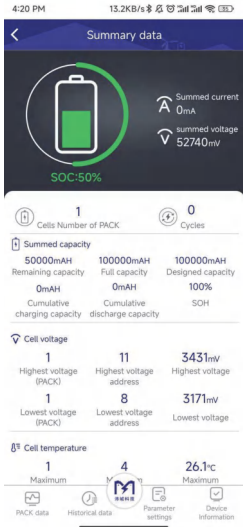

5.5.11 OTA upgrade

According to the functions supported by serial port protocol 0.0.9, except for the protocol itself, the summary interface, basic data, voltage and temperature, state data, historical data, parameter setting, equipment information, general setting, etc

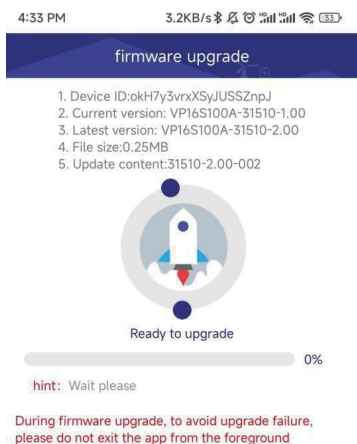
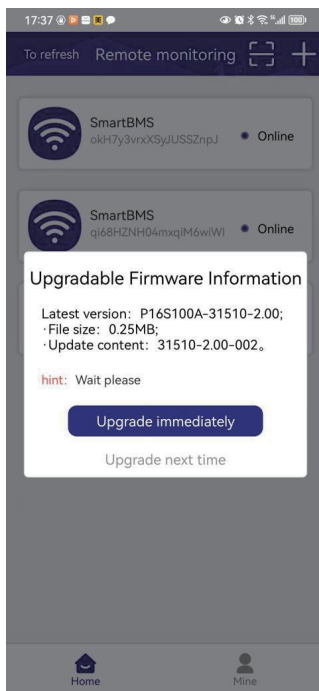
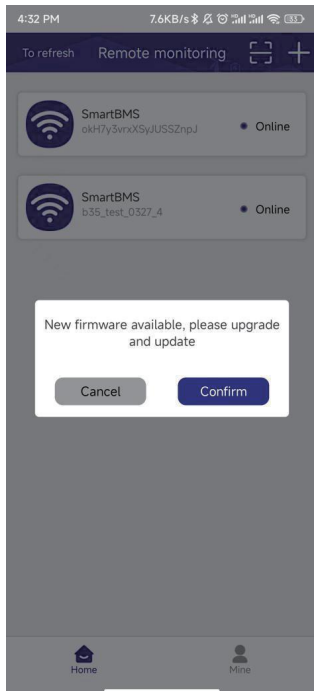

5.5.12 Account exit and logout

Account exit: after exit, you can switch to other accounts for login
Account cancellation: Once cancelled, all the information and binding relationship of the account will be cleared, and you need to be re-registered next time

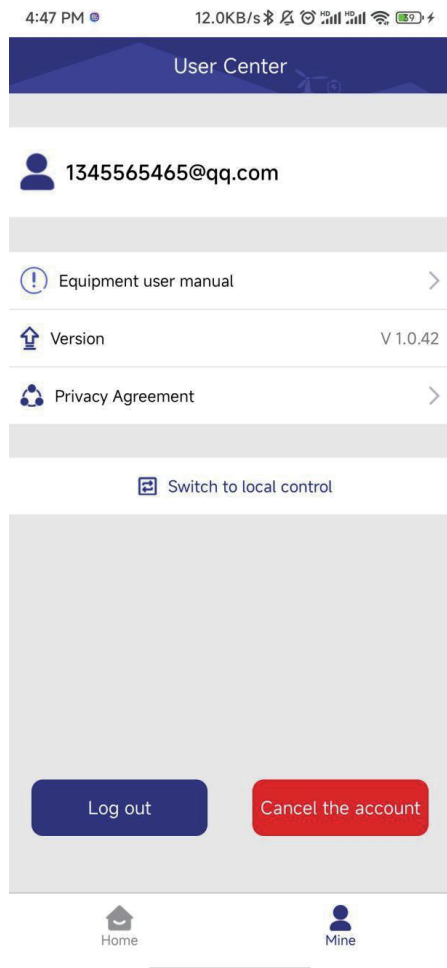

VI. Installation

6.1 Preparation

6.1.1 Safety Compliance

The system installation must be finished by qualified person(s). During the whole installation process, please strictly follow the local safety regulations and related operating procedures.

6.1.2 Environment

The operating environment shall meet the following requirements:

Category	Description
Working temperature	-20°C-55°C(maximum operating range) 15°C-30°C (optimal temperature)
Relative humidity	5%~90%, No condensation
Altitude	<3000m
Safety requirement	<ul style="list-style-type: none">· Do not expose the battery to direct sunlight, rain and snow.· Do not place the battery within children/pet touchable area.· Do not place the battery near heat source and flammable material· Do not place the battery in a closed place where the ventilation is not available.· Do not drop, deform, impact, cut or spearing with a sharp object.· Do not put heavy things on battery.· Do not disassemble the battery without Manufacturer's permission.· No conductive dust and water or other liquid to contact battery.· Follow the emergency measure if there is water invasion or electrolyte and gas leakage.· Contact your supplier within 24 hours if any product failure happens.

6.1.3 Tools



Tools	
Screwdriver (slot, cross)	Multi-meter
Wrench	Clamp meters
Diagonal pliers	Insulating tape
Needle nose pliers	Thermometer (observe the installation environment)
Clamping pliers	Anti-static bracelet
Wire stripper	cable ties



6.2 Inspection

6.2.1 Unpack precautions

- * Please load and unload it in accordance with the specified requirements to prevent sun and rain when you receive the equipment.
- * Please check and confirm the goods (such as quantity, appearance, etc.) according to the "scope of delivery " before unpacking.
- * Do light take and put during unpacking process to protect the surface coating of the object;
- * Please record and contact to the manufacturer if the inner packing is damaged after unpacking.

6.2.2 Scope of delivery

General materials		
 <p>Battery Pack *1pcs</p>	 <p>Manual *1pcs</p>	 <p>Communication cable *1pcs</p>

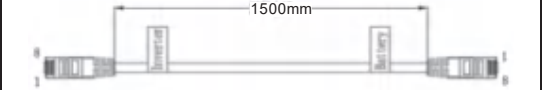
Type	Detail	Qty.
Cables	<p>A: Battery to Inverter positive cable(2AWG 1200mm BLACK)</p> 	1pcs
	<p>B: Battery to Inverter positive cable(2AWG 1200mm RED)</p> 	1pcs
Communication Cables	<p>C: Battery to Inverter communication cable (1500mm)</p> 	1pcs

 **NOTICE**
 Keep the unused cable pins NULL to avoid affecting the closed loop communication.

 **NOTICE**
 A ground connection of communication cable may be required from some inverters, please follow the rules from inverter manufacture.

6.3 Start Installation

Qualified person

6.3.1 Reminder

Before installation, please double check if the following conditions or equipment meet the requirements:

- *Check if there is enough installation space and if the ground is flat enough
- *Check if the power cords used meet the maximum current requirements for operation;
- *Check whether the overall layout of power supply equipment and batteries on the construction site is reasonable;
- *Check if the installation personnel are wearing anti-static wristbands
- *Check if there are two people performing installation work on the construction site
- *Check the installation site for potential risks such as flooding, sun exposure, corrosion, and salt spray

6.3.2 Procedures



Injuries may result if the product is lifted incorrectly or dropped while being transported or mounted. Wear suitable personal protective equipment for all work on the product.



Ensure that no lines are laid in the wall which could be damaged when drilling holes.

6.3.2.1 Unbox

1. Remove the battery from the wooden box.
2. Prepare the battery and place it horizontally in a reasonable position with the wheels facing down.
3. Rotate the red gear of the wheel clockwise, and then move the battery to the installation location.
4. Rotate the red gear counterclockwise to fix the wheel.
5. Complete the cable connection.

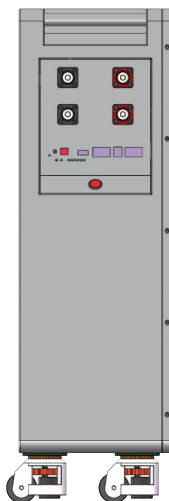

NOTICE

ANY others installations, please avoid the battery directly contacting the ground and avoid of high salinity, humidity to prevent the product from rusting and corrosion.

VII.Cable Connection and Commissioning

Qualified person

7.1 Get Battery Ready

7.1.1 Ensure all the battery is in OFF mode, and confirm the installation is tighten and stable.

7.1.2 Check the number and specification of cable kit accessories are correct according to the Scope of delivery item, if you are making cable yourself, please follow manufacturer's requirements.

7.1.3 Switch on all battery individually, check whether there is any alarm/protection information, if yes, turns to troubleshooting. Then switch off all batter

7.2 Communication Cable Connection

7.2.1 Take out battery to battery communication cable.

7.2.2 Confirm the location of Master battery, insert the RJ45 plug into the Link Out port and connect the other side to next battery Link IN port, chained all batteries.

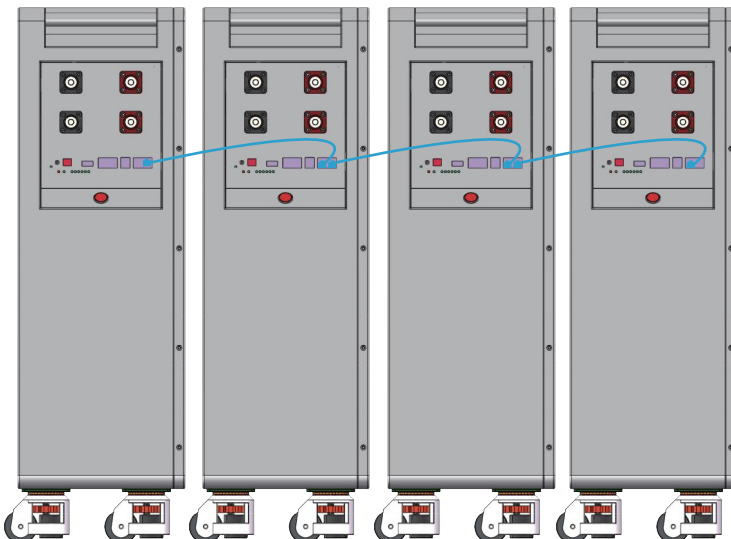

7.3 DC Power Cable Connection

7.3.1 Take out battery to battery power cable.

7.3.2 Use the M8 screws on the battery to fix the battery connection wire and install the insulating protective cover.

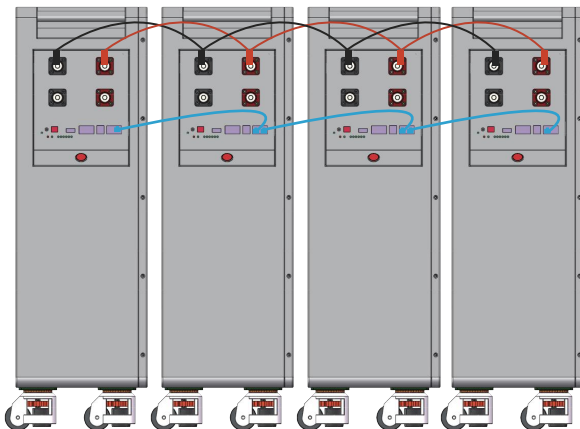

7.4 Connecting with Inverter

7.4.1 Connecting Master battery Link IN port with inverter CAN or RS485 communication port via inverter communication cable.

7.4.2 Connecting battery OUTPUT (+) with inverter battery INPUT (+), battery OUTPUT (-) with inverter battery INPUT (-), an external disconnection breaker between battery system and inverter is recommended, choose the corresponding power cable pair and wiring them correctly.



CAUTION

Confirm inverter AC input and PV input is disconnected before wiring connection, and the DC/ signal switch of inverter/ is in off status.



NOTE

Choose the suitable disconnection breaker considering the inverter power/current, rated voltage, tripping characteristic etc.

Wiring diagram allowed:

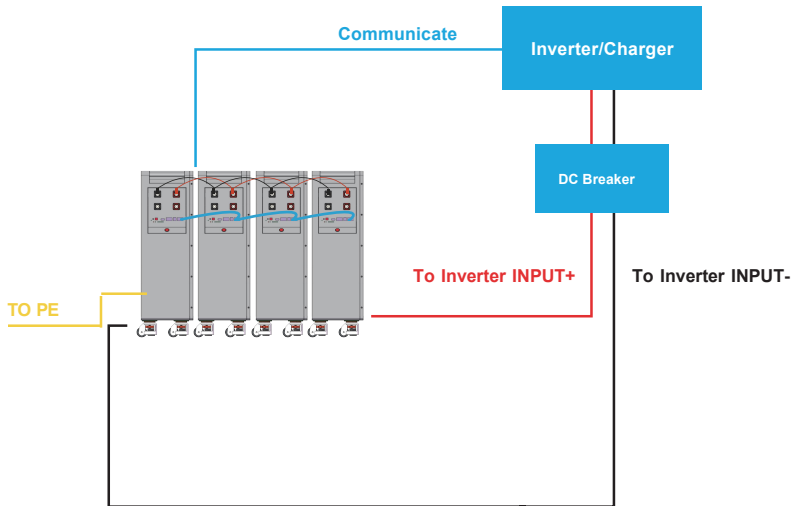

NOTICE

The maximum communication cable length is required to be less than 15m between inverter/charge and battery.







The maximum power cable length is suggested to be less than 10m between inverter/charge and battery.

For other type of installation, please also follow the rules above to wiring your system.

CAUTION

The maximum tolerance current of each power cable and terminal is 125A, 100A for continuously is suggested, please use corresponding number of power cable pairs according to the field configuration and local connection requirements, standards, and directives.

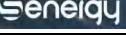
7.5 Adaptation inverter list

Inverter Brand		Model	Battery Protocol Selection	Battery Modules
	JUMLEE	LV ALL	RS485-PYLON	15
	JUMLEE IP65	LV ALL	CAN-PYLON	15
	PYLON	LV ALL	CAN-PYLON	15
	GOODWE	LV ALL	CAN-Goodwe	15
	GROWATT	LV ALL	CAN-Growatt	15
	SMA	LV ALL	CAN-SMA	15
	VICTRON	LV ALL	CAN-Victron	15
	TBB	LV ALL	CAN-TBB	15
	MUST	LV ALL	CAN-MUST	15
	SRNE	LV ALL	RS485-WOW	15
	DEYE	LV ALL	CAN-PYLON	15
	INVT	LV ALL	CAN-PYLON	15
	VOLTRONIC	LV ALL	RS485-Voltronic	15
	SOROTEC	LV ALL	CAN-Sorotec	15
	LUXPOWER	LV ALL	CAN-Luxpower	15
	SOLIS	LV ALL	CAN-PYLON	15
	MEGAREVO	LV ALL	CAN-PYLON	15
	AISWEI	LV ALL	CAN-Solar	15
	TECHFINE	LV ALL	RS485-PYLON	15
	SACOLAR	LV ALL	RS485-Growatt	15
	SCHNEIDER	LV ALL	CAN-Schneider	15
	STUDER	LV ALL	CAN-STUDER	15
	SENERGY	LV ALL	CAN-Senergy	15
	SMK	LV ALL	RS485-PYLON	15
	SAKO	LV ALL	RS485-PYLON	15
	INHENERGY	LV ALL	CAN-PYLON	15
	AFORE	LV ALL	CAN-PYLON	15
	FELICITYSOLAR	LV ALL	CAN-PYLON	15

7.6 Commissioning

7.6.1 Set the DIP address of the Master battery (and the Slave battery if there is any RS485 baud rate change).

7.6.2 Switch on all battery modules, wait 1 minute, and make sure that ON/OFF led is on Master battery.

7.6.3 Turn on the breaker between the inverter and battery if there is any, then turn on the inverter/charger isolation.

7.5.4 Finish the setting on inverter/charger or any other control devices. If everything is correct, you are ready to use the system.



CAUTION

If your system is an back-up or off-grid system, make sure your configuration can cover the worst situation to avoid battery to be over-discharged.

7.7 Switch off Battery

7.7.1 Turn off the inverter.

7.7.2 Turn off the disconnection breaker if there is any.

7.7.3 Turn off all batteries power switch

VIII.Troubleshooting

Items	Solution	Measure
Unable to start	<ol style="list-style-type: none"> 1. Switch on battery and press RESET 6s to observe whether the battery can be started. 2. Charge the battery use a charge or inverter to provide 54~57.6V voltage and observe it can be started. 	<p>If the abnormal status still alive after above steps, please contact your supplier.</p> <p>If there is any other situation(s) excluding in this table, turn off the fault battery, contact your supplier.</p>
Unable to charge	<ol style="list-style-type: none"> 1. Check whether the cable connection between the battery and the inverter/charger is correct. 2. Check whether the inverter/charger setting is correct. 3. Check whether the battery is in charge protection mode, if yes, try to discharge the battery. 	
Unable to discharge	<ol style="list-style-type: none"> 1. Check whether the cable connection between the battery and the inverter/charger is correct 2. Check whether the battery occurs short circuit, reverse connection, pre-charge failure during connection inverter etc. 3. Check whether the battery is in discharge protection mode, if yes, try to charge the battery. 	
High/Low temperature	<ol style="list-style-type: none"> 1. Stop the battery system for a while, check whether the installation location temperature meet the requirement. 2. Avoid continuous full charging and discharging 	
High current	Check the configuration and parameters setting on the inverter/charger is correct.	
ALM ON	Turn off all the batteries, and remove the fault battery from the system.	
Communication fail	<ol style="list-style-type: none"> 1. Check the communication cable type is correct and is contacted well. 2. Check the DIP switch setting is correct. 3. Check the inverter protocol related setting is correct. 4. Check both battery and inverter are working properly. 	



NOTICE

Please restart after software is upgraded.

IX. Transport and Storage

- * Do not violently shake, impact or squeeze, and prevent sun and rain during the transportation.
- * Do not light take and put and strictly prevent falling, rolling, and heavy pressure during loading and unloading.
- * The battery should be placed in a dry, clean, dark, and well ventilated indoor environment for long- term storage, and the recommended storage temperature range is 15~30°C .
- * No harmful gases, flammable and explosive products and corrosive chemical substances in the storage location.
- * The batteries should be stored and transported in close to 50% SOC, and do not store over 80% SOC for longtime.
- * If do not use for a time, The battery needs to be charged every 6 months if it is not used for a long time.
- * No fall down, no pile up.

X. Disposal of Battery

Disposal of battery must comply with the local applicable disposal regulations for electronic waste and used batteries, Please review your local Battery recycling or management regulations or contact us for more information.